

PCTWORLD INTELLECTUAL PROPERTY ORGANIZATION
International Bureau

INTERNATIONAL APPLICATION PUBLISHED UNDER THE PATENT COOPERATION TREATY (PCT)

(51) International Patent Classification ⁶ : A01N 43/04, A61K 31/70, 48/00, C07H 21/04, C12N 5/10, 15/12, 15/85	A1	(11) International Publication Number: WO 97/40679 (43) International Publication Date: 6 November 1997 (06.11.97)
(21) International Application Number: PCT/US97/07237 (22) International Filing Date: 30 April 1997 (30.04.97) (30) Priority Data: 08/640,554 1 May 1996 (01.05.96) US 08/785,661 17 January 1997 (17.01.97) US 08/841,169 29 April 1997 (29.04.97) US (71) Applicant: IMARX PHARMACEUTICAL CORP. [US/US]; 1635 East 18th Street, Tucson, AZ 85749 (US). (72) Inventor: UNGER, Evan, C.; 13365 East Camino La Cebadilla, Tucson, AZ 85749 (US). (74) Agent: MILLER, Suzanne, E.; Woodcock Washburn Kurtz Mackiewicz & Norris, 46th floor, One Liberty Place, Philadelphia, PA 19103 (US).	(81) Designated States: AU, BR, CA, CN, HU, JP, KR, MX, NO, European patent (AT, BE, CH, DE, DK, ES, FI, FR, GB, GR, IE, IT, LU, MC, NL, PT, SE). Published <i>With international search report.</i>	
(54) Title: METHODS FOR DELIVERING COMPOUNDS INTO A CELL (57) Abstract The present invention is directed, <i>inter alia</i> , to a method for delivering a compound into a cell comprising administering to the cell the compound to be delivered, an organic halide, and/or a carrier. Ultrasound may also be applied, if desired.		

FOR THE PURPOSES OF INFORMATION ONLY

Codes used to identify States party to the PCT on the front pages of pamphlets publishing international applications under the PCT.

AL	Albania	ES	Spain	LS	Lesotho	SI	Slovenia
AM	Armenia	FI	Finland	LT	Lithuania	SK	Slovakia
AT	Austria	FR	France	LU	Luxembourg	SN	Senegal
AU	Australia	GA	Gabon	LV	Latvia	SZ	Swaziland
AZ	Azerbaijan	GB	United Kingdom	MC	Monaco	TD	Chad
BA	Bosnia and Herzegovina	GE	Georgia	MD	Republic of Moldova	TG	Togo
BB	Barbados	GH	Ghana	MG	Madagascar	TJ	Tajikistan
BE	Belgium	GN	Guinea	MK	The former Yugoslav Republic of Macedonia	TM	Turkmenistan
BF	Burkina Faso	GR	Greece			TR	Turkey
BG	Bulgaria	HU	Hungary	ML	Mali	TT	Trinidad and Tobago
BJ	Benin	IE	Ireland	MN	Mongolia	UA	Ukraine
BR	Brazil	IL	Israel	MR	Mauritania	UG	Uganda
BY	Belarus	IS	Iceland	MW	Malawi	US	United States of America
CA	Canada	IT	Italy	MX	Mexico	UZ	Uzbekistan
CF	Central African Republic	JP	Japan	NE	Niger	VN	Viet Nam
CG	Congo	KE	Kenya	NL	Netherlands	YU	Yugoslavia
CH	Switzerland	KG	Kyrgyzstan	NO	Norway	ZW	Zimbabwe
CI	Côte d'Ivoire	KP	Democratic People's Republic of Korea	NZ	New Zealand		
CM	Cameroon		Republic of Korea	PL	Poland		
CN	China	KR	Republic of Korea	PT	Portugal		
CU	Cuba	KZ	Kazakistan	RO	Romania		
CZ	Czech Republic	LC	Saint Lucia	RU	Russian Federation		
DE	Germany	LJ	Liechtenstein	SD	Sudan		
DK	Denmark	LK	Sri Lanka	SE	Sweden		
EE	Estonia	LR	Liberia	SG	Singapore		

Title

METHODS FOR DELIVERING COMPOUNDS INTO A CELL

Related Applications

This application is a continuation-in-part of U.S. application Serial No. 5 08/785,661, filed January 17, 1997, which in turn is a continuation-in-part of U.S. application Serial No. 08/640,554, filed May 1, 1996, the disclosures of each of which are hereby incorporated herein by reference in their entireties.

Field of the Invention

This invention relates to the field of intracellular delivery, in particular, 10 to the use of organic halides and/or ultrasound to facilitate the delivery of a compound into a cell.

Background of the Invention

Cells are the basic structural and functional units of all living organisms. All cells contain cytoplasm surrounded by a plasma, or cell, membrane. Most 15 bacterial and plant cells are enclosed in an outer rigid or semi-rigid cell wall. The cells contain DNA which may be arranged in 1) a nuclear membrane or 2) free in cells lacking a nucleus. While the cell membrane is known to contain naturally occurring ion channels, compounds that are therapeutically advantageous to cells are usually too large to pass through the naturally occurring ion channels. Conventional interventional 20 methods of delivery of compounds into cells have proved difficult in view of the need

for the compounds to pass through the cell membrane, cell wall, and nuclear membrane.

Molecular biology has resulted in mapping the genomes of many plants and animals including the mapping of much of the human genome. The potential for
5 advances in the understanding of the genetic basis of diseases is great, as is the potential for the development of therapies to treat such diseases. However, to fully take advantage of these advancements and treatment therapies, methods are needed which will allow for the delivery of desired compounds into the target cells. Accordingly, researchers have undertaken the development of a variety of intracellular
10 delivery methods for inserting genes and other compounds into both plant and animal cells.

For example, calcium phosphate DNA precipitation has been used to deliver genetic material into cells in cell culture. However, one drawback of this method is that the resultant efficiency of transfection (delivery of the genetic material
15 into the cells) and subsequent gene expression has been very low.

Improved transfection has been attained using viral vectors, e.g., adenovirus and retrovirus, but again, difficulties with gene expression have persisted. In addition, substantial concerns regarding antigenicity and the potential of mutant
20 viruses and other possible deleterious effects exist.

Liposomes, manufactured more easily than viral vectors, have shown promise as gene delivery agents. Liposomes have less biological concerns (in that, for example, they are generally non-antigenic) but the efficiency of transfection and gene
expression using liposomes has typically been lower than with viruses.

Gene guns, wherein genes are attached to heavy metal particles such as
25 gold, have been used to fire the particles at high speed into cells. However, while gene guns have resulted in gene expression in culture systems, they have not worked well *in vivo*. Furthermore, the blast of heavy metal particles may cause damage to the cells and may result in the introduction of undesirable foreign materials, e.g. gold particle fragments, into the cells.

30 Electroporation is another method of delivering genes into cells. In this technique, pulses of electrical energy are applied to cells to create pores or openings to

facilitate passage of DNA into the cells. However, electroporation may damage cells, and furthermore has not been shown to be highly effective *in vivo*.

Various publications disclose the use of lithotripsy shock waves for effecting intracellular gene transfer, as well as the delivery of other compounds, including, for example, Delius, M., *et al.*, "Extracorporeal Shock Waves for Gene Therapy," *Lancet* May 27, 1995, 345:1377; Lauer, U., *et al.*, "Towards A New Gene Transfer System: Shock Wave-Mediated DNA Transfer," *J Cell Biochem* 1994, 16A:226; Gambihler, S., *et al.*, "Permeabilization of the Plasma Membrane of L1210 Mouse Leukemia Cells Using Lithotripter Shock Waves," *J Membr Biol* 1994, 10 141:267-75; and Mobley, T.B., *et al.*, "Low Energy Lithotripsy with the Lithostar: Treatment Results with 19,962 Genal and Ureteral Calculi," *J Urol* 1993, 149:1419-24. Lithotripsy delivers energy in the range of 200-380 bars, and a frequency of 60-120 Hz, but may be as high as 1200 to 1300 bars. The energy and frequency ranges are typically painful to a patient and thus usually require patient sedation. Lithotripsy machines are large and bulky and are typically cost prohibitive. Lauer *et al.* disclose 15 the delivery of 250 shock waves at 25 kV with a lithotripter to deliver plasmid DNA which expressed hepatitis B virus surface proteins in a HeLa cell suspension. Gambihler *et al.* (cited above) teach the permeabilization of mouse cells *in vitro* to deliver dextrans. The lithotripter shock waves are delivered at 25 kV, at a discharge 20 rate of 60/min. Mobley *et al.* (cited above) disclose the use of lithotripsy to treat renal and ureteral stones. The shock wave pressure was 200 to 380 bar and a generator range of 10 to 29 kV.

Zhang, L., *et al.*, "Ultrasonic direct gene transfer The Establishment of High Efficiency Genetic Transformation System for Tobacco," *Sci Agric. Sin.* 1991, 25 24:83-89 disclose increased gene expression by tobacco using continuous wave ultrasound at 0.5 W/cm² for 30 minutes. Zhang *et al.* do not disclose the ultrasound frequency. The high energy level is in a range necessary for poration to result in the cell wall of tobacco plants.

Rubin, *et al.*, 31st Annual Meeting of the American Society of Clinical 30 Oncology, May 20-23, 1995, disclose the injection of hepatic tumors with a plasmid/cationic lipid complex with ultrasound guidance. Ultrasound is disclosed as a

visual guide to monitor the injection of the tumors, rather than as an aid to deliver the complex to the liver tumors.

The present invention provides new and/or better methods for delivering compounds, including genetic material, into a cell. The methods of the present
5 invention may provide a significant advantage over prior art methodology, in that enhanced levels of intracellular delivery, and in the case of nucleotides, gene expression, may be achieved. In addition, the process of the present invention may be performed in cell lines which may be otherwise resistant to intracellular delivery and gene expression using other conventional means. These and/or other aspects of the
10 present invention will become apparent from the further discussions herein.

Summary of the Invention

The present invention is directed, *inter alia*, to a method for delivering a compound into a cell comprising administering to the cell a composition which comprises the compound to be delivered and an organic halide.

15 In addition, the invention provides a method of treating a patient comprising administering to a patient a composition comprising a therapeutically effective amount of a compound and an organic halide.

The subject invention provides a method of effecting the expression of a nucleotide sequence in a cell comprising administering to said cell a composition which
20 comprises a nucleotide sequence and an organic halide.

If desired, the compositions may further comprise a carrier. In addition, the method of the invention may further comprise the application of ultrasound, as desired.

The present invention is also directed to a method for delivering a
25 compound into a cell comprising administering to the cell the compound to be delivered, or a composition comprising the compound to be delivered, and applying ultrasound.

Further, the invention pertains to a method of treating a patient comprising administering to a patient a therapeutically effective amount of a
30 compound, or a composition comprising a therapeutically effective amount of a compound, and applying ultrasound.

Moreover, the subject invention provides a method of effecting the expression of a nucleotide sequence in a cell comprising administering to the cell a nucleotide sequence, or a composition which comprises a nucleotide sequence, and applying ultrasound.

5 If desired, the composition may further comprise carrier.

Also included in the present invention are compositions and kits comprising, for example, a therapeutically effective or diagnostically effective amount of a compound to be delivered, an organic halide, and/or a carrier, and, in the case of a kit, optionally other conventional kit components.

10 These, as well as other, aspects of the invention are set forth in greater detail below.

Brief Description of the Figures

FIGURE 1 depicts a test set-up for delivery of compounds to a cell *in vitro* or *ex vivo*. In Figure 1, A represents a standoff platform. B is a six well plate, with individual wells B'. C represents an ultrasound gel, while D represents a therapeutic ultrasound transducer. In accordance with the invention, cells, the compound to be delivered, an organic halide (if desired), and optionally a carrier are placed in the wells. Using ultrasound transducer D, ultrasound is then applied to cell culture plate B such that the standoff platform (A) is cut (G) under each well (B') for focusing ultrasound to the individual wells (B'). Ultrasound transducer D may also be employed for the *in vivo* delivery of compounds by applying transducer D, with ultrasound gel C, to a patient instead of to a cell culture plate.

FIGURE 2 displays the relationship between energy deposition, ultrasound energy intensity, and ultrasound duty cycle (pulse duration). The effect of attenuation as a function of tissue depth is also portrayed as well as spatial peak temporal average power.

FIGURE 3 is a map of the pCAT[®] control vector (GenBank accession number X65321) (Promega, Madison, WI) used in the preparation of sequences introduced into cells in Examples 2 and 3.

30 **FIGURE 4** is a cutaway from FIGURE 1, depicting one of the six wells (B') of a six well plate B. In FIGURE 4, A is a portion of the standoff platform, B' is

one well of six well plate B, C is the ultrasound gel, D is the ultrasound transducer, E represents the cells, and F represents microsphere carriers for the compound to be delivered.

FIGURE 5 is a prototype second harmonic transducer that emits X and
5 2X frequencies and superimposes two beams at one focal point for enhanced ultrasound effect. The transducer may be employed in conjunction with *in vitro*, *ex vivo* and *in vivo* delivery of compounds and compositions in accordance with the invention.

FIGURE 6 is a map of the pCAT[®] basic vector (Promega, Montgomeryville, PA) used in the preparation of sequences introduced into cells in
10 Example 10.

FIGURE 7 depicts the results of the *in vivo* transfection studies in mice set forth in Example 23.

Detailed Description of the Invention

As employed above and throughout the disclosure, the following terms,
15 unless otherwise indicated, shall be understood to have the following meanings.

For purposes of the present invention, an "organic halide" (also sometimes referred to as a halogenated organic compound) denotes a compound which contains at least one carbon atom (or optionally sulfur or selenium atom, such as in the case of SF₆ and SeF₆) and at least one halogen atom selected from the group consisting
20 of fluorine, chlorine, bromine, or iodine. Preferably the halogen is fluorine (i.e., the compound is a fluorinated compound).

Most preferably the organic halide is a fluorinated compound which is perfluorinated (that is, fully fluorinated, e.g., a carbon compound wherein all hydrogen atoms directly attached to the carbon atoms have been replaced by fluorine atoms).
25 The perfluorinated organic halide (perfluorinated compound) is preferably a perfluorocarbon or a perfluoroether. The organic halide may be in the form of a gas, a liquid (including a gaseous precursor), or a solid. Preferably the organic halide is a liquid, even more preferably a liquid which is a gaseous precursor that converts to a gas upon administration. Most preferably, the gaseous precursor converts to a gas at
30 the site of (in close or touching proximity to) the cell.

"Gaseous precursor" refers to a liquid or solid which is activated upon attaining a certain temperature or pressure to convert to a gas. A gaseous precursor which is capable of converting to a gas at the site of the cell may increase the efficiency of cellular uptake of compounds, and is therefore preferred.

5 Ideally, the gaseous precursors are liquid (or solid) at ambient (room) temperature (e.g., 25°C), but will convert to a gas either at physiological temperature (e.g., 37°C) such as upon administration to a patient, or otherwise conveniently at the site of the cell such as upon application of heat (such as, for example, using
10 ultrasound). If heat is applied, it should be done so at a temperature sufficient to convert the gaseous precursor to a gas, but insufficient to harm the cell (e.g., denature the proteins, etc.). Thus, ideally a gaseous precursor becomes a gas at less than about 80°C. Even more ideally, the gaseous precursor becomes a gas at between about 30°C and about 70°C. Most ideally, the gaseous precursor becomes a gas at between about 37°C and less than about 50°C.

15 A variety of different organic halides may be employed in this invention. Where the organic halide is a carbon based halide compound, the organic halide preferably contains from 1 to about 30 carbon atoms, more preferably 1 to about 24 carbon atoms, even more preferably 1 to about 12 carbon atoms, still even more preferably about 5 to about 12 carbon atoms, and most preferably about 6 to about 10
20 carbon atoms. Thus, the number of carbon atoms in the organic halide may be 1, 2, 3, 4, 5, 6, 7, 8, 9, 10, 11, 12, 13, 14, 15, 16, 17, 18, 19, 20, 21, 22, 23, 24, carbon atoms, and upwards. Sulfur or selenium based halide compounds, such as sulfur hexafluoride and selenium hexafluoride, are also within the scope of the invention and the phrase organic halide as used herein. The organic halides contemplated herein may
25 also, for example, have carbon atoms interrupted by one or more heteroatoms, such as -O- bonds (as in ether compounds) or have other substituents such as amines, etc. Preferred organic halides of the present invention are the perfluorinated organic halides such as perfluorocarbons and perfluoroethers.

30 Table 1 lists representative organic halides useful in the present invention. Other organic halides suitable for use in the present invention will be readily apparent to one skilled in the art, once armed with the present disclosure. All

such organic halides are intended to fall within the scope of the term organic halide, as used herein.

Table 1

Organic Halides

<u>5</u>	<u>Compound</u>	<u>Boiling Point (°C)</u>
	<u>1. Mixed-halogenated Compounds</u>	
	1-bromo-nonafluorobutane	43
	perfluorooctyl iodide	160-161
	perfluorooctyl bromide	142
10	1-chloro-1-fluoro-1-bromomethane	38
	1,1,1-trichloro-2,2,2-trifluoroethane	45.7
	1,2-dichloro-2,2-difluoroethane	46
	1,1-dichloro-1,2-difluoroethane	45
	1,2-dichloro-1,1,3-trifluoropropane	50.4
15	1-bromoperfluorobutane	43
	1-bromo-2,4-difluorobenzene	44
	2-iodo-1,1,1-trifluoroethane	53
	5-bromovaleryl chloride	43
	1,3-dichlorotetrafluoroacetone	43
20	bromine pentafluoride	40.3
	1-bromo-1,1,2,3,3,3-hexafluoropropane	35.5
	2-chloro 1,1,1,4,4,4-hexafluoro-2-butene	33
	2-chloropentafluoro-1,3-butadiene	37
	iodotrifluoroethylene	30
25	1,1,2-trifluoro-2-chloroethane	30
	1,2-difluorochloroethane	35.5
	1,1-difluoro-2-chloroethane	35.1
	1,1-dichlorofluoroethane	31.8
	heptafluoro-2-iodopropane	39
30	bromotrifluoroethane	-57.8

- 9 -

	chlorotrifluoromethane	-81.5
	dichlorodifluoromethane	-29.8
	dibromofluoromethane	23
	chloropentafluoroethane	-38.7
5	bromochlorodifluoromethane	-4
	dichloro-1,1,2,2-tetrafluoroethane	3.1-3.6
	 <u>2. Fluorinated Compounds</u>	
	1,1,1,3,3-pentafluoropentane	40
	perfluorotributylamine	178
10	perfluorotripropylamine	130
	3-fluorobenzaldehyde	56
	2-fluoro-5-nitrotoluene	53
	3-fluorostyrene	40
	3,5-difluoroaniline	40
15	2,2,2-trifluoroethylacrylate	45
	3-(trifluoromethoxy)-acetophenone	49
	1,1,2,2,3,3,4,4-octafluorobutane	44.8
	1,1,1,3,3-pentafluorobutane	40
	1-fluorobutane	32.5
20	1,1,2,2,3,3,4,4-octafluorobutane	44.8
	1,1,1,3,3-pentafluorobutane	40
	perfluoro-4 methylquinolizidine	149
	perfluoro-N-methyl-decahydroquinone	150-155
	perfluoro-N-methyl-decahydroisoquinone	150-155
25	perfluoro-N-cyclohexyl-pyrrolidine	145-152
	tetradecaperfluoroheptane	76
	dodecaperfluorocyclohexane	52

3. Perfluorinated Compoundsa. Perfluorocarbons

	perfluoromethane	-129
	perfluoroethane	-78.3
5	perfluoropropane	-36
	perfluorobutane	-2
	perfluoropentane	29.5
	perfluorohexane	59-60
	perfluoroheptane	81
10	perfluorooctane	102
	perfluorononane	125
	perfluorodecane	~ 143
	perfluorododecane	melting pt 75-77
	perfluoro-2-methyl-2-pentene	51
15	perfluorocyclohexane	52
	perfluorodecalin	142
	perfluorododecalin	---
	perfluoropropylene	-28
	perfluorocyclobutane	-6
20	perfluoro-2-butyne	-25
	perfluoro-2-butene	1.2
	perfluorobuta-1,3-diene	6

b. Perfluoroether Compounds

	perfluorobutylethyl ether	60
25	bis(perfluoroisopropyl) ether	54
	bis(perfluoropropyl) ether	59
	perfluorotetrahydropyran	34
	perfluoromethyl tetrahydrofuran	27
	perfluoro t-butyl methyl ether	36
30	perfluoro isobutyl methyl ether	---
	perfluoro n-butyl methyl ether	35.4

- 11 -

	perfluoro isopropyl ethyl ether	---
	perfluoro n-propyl ethyl ether	23.3
	perfluoro cyclobutyl methyl ether	---
	perfluoro cyclopropyl ethyl ether	---
5	perfluoro isopropyl methyl ether	36
	perfluoro n-propyl methyl ether	---
	perfluoro diethyl ether	3-4.5
	perfluoro cyclopropyl methyl ether	---
	perfluoro methyl ethyl ether	-23
10	perfluoro dimethyl ether	-59

c. Other

	sulfur hexafluoride	m.p. -50.5, sublimes -63.8
15	selenium hexafluoride	m.p. -34.6 sublimes -46.6

Preferred organic halides include 1-bromo-nonafluorobutane, 1,1,1,3,3-pentafluoropentane, perfluorohexane, perfluorocyclohexane, 1-bromo-1,1,2,3,3,3-hexafluoropropane, heptafluoro-2-iodopropane, 1,1,2,2,3,3,4,4-octafluorobutane, 1-fluorobutane, tetradecaperfluoroheptane and dodecaperfluorocyclohexane. Particularly preferred are perfluorohexane (especially n-perfluorohexane) and perfluorocyclohexane. A wide variety of other organic halides useful in the present invention will be readily apparent to those of skill in the art once armed with the present disclosure. Suitable additional organic halides include those, for example, disclosed in Long, Jr. in U.S. Patent Nos. 4,987,154, 4,927,623, and 4,865,836, the disclosures of each of which are hereby incorporated herein by reference in their entirety.

The amount of organic halide employed in the present invention may vary, as one skilled in the art will recognize, once armed with the present disclosure, and may be dependent on such factors as the particular organic halide employed, type and nature of the compound to be delivered, the age, weight, cells or patient (animal) to be treated, the particular diagnostic, therapeutic or other application intended

(including the disease state, if any, to be treated). Typically lower amounts are used and then increased until the desired delivery effect is achieved. Representative amounts are set forth in the examples herein. Of course, higher or lower amounts may be employed, as will be recognized by the skilled artisan.

5 Methods of introducing compounds into a cell (also referred to variously herein as methods for delivering a compound into a cell, methods of intracellular delivery, methods of promoting, effecting, facilitating or enhancing the uptake of a compound into a cell, and the like) include "transfection", which refers to the introduction of genetic material, i.e., a nucleotide sequence (e.g., DNA or RNA) into
10 a host cell. Transfection is also sometimes referred to as transformation. DNA (or RNA) which is new to the cell into which it is incorporated is typically referred to as heterologous DNA (or RNA) or exogenous DNA (or RNA). Some bacterial species take up exogenous DNA and do not discriminate between uptake of DNA from a similar or same species or from a completely different species or organism.
15 Exogenous DNA may also be taken up by cells, but may or may not be incorporated into nuclear material in a heritable manner. The objective of transfection of a host cell may be to effect expression of one or more carefully selected sequences.

"Expression" and "gene expression" refer to the transcription and/or translation of a nucleic acid sequence resulting in the production of an amino acid,
20 peptide and/or protein. The nucleic acid sequence may or may not be incorporated into the genetic material of the host cell. For example, the nucleic acid sequence may be incorporated into the genome of a host cell or may simply be introduced into the cell without incorporation into the genome.

Gene expression, upon administration of the composition of the present
25 invention, may be effected (obtained, promoted, facilitated or enhanced), and in fact may be enhanced in that the expression of the nucleic acid sequences as compared to conventional transfection techniques such as calcium phosphate precipitation, viral vectors, microinjection, shock wave such as for example lithotripsy, and electroporation, may be increased. Methods of measuring enhanced gene expression
30 will be known to skilled artisans once armed with the present disclosure and include enzyme-linked immunosorbent assay (ELISA) as well as methods disclosed in Sambrook, *et al.*, *Molecular Cloning: A Laboratory Manual*, 2nd ed., Cold Spring

Harbor Laboratory Press, Cold Spring Harbor, NY (1989), the disclosures of which are hereby incorporated herein by reference in their entirety. Thus, as a result of the methods of the present invention, a product (e.g., a protein) may be produced. In addition, the prevention of the production of a product (such as, as a result of an antisense sequence delivered into the cell) by the host cell may also result.

Without being bound by any theory of operation, it is believed that delivery of nucleic acid sequences and other compounds in accordance with the methods of the present invention may induce a cell to take up the compound to be delivered thereto. Included within the definition of delivery of a compound into a cell in accordance with the methods of the present invention are active and passive mechanisms of cellular uptake. Ion channels and other means of transport utilized by cells to incorporate extracellular materials, including compounds to be delivered thereto, into the intracellular milieu are encompassed by the present invention.

"Nucleotide sequence and nucleic acid sequence" refer to single and double stranded DNA and RNA sequences, including and not limited to oligonucleotide sequences of about 100 kb to about 1,000,000 kb (including whole chromosomes), preferably of about 4 kb to about 6 kb, more preferably about 1,000 nucleotides in length, more preferably about 500 nucleotides in length, more preferably about 250 nucleotides in length, more preferably about 100 nucleotides in length, more preferably about 50 nucleotides in length, more preferably about 25 nucleotides in length, more preferably about 10 nucleotides in length, even more preferably about 3 to about 10 kbp in length. Embodied by the term "nucleotide sequence" are all or part of a gene, at least a portion of a gene, a gene fragment, a sense sequence, an antisense sequence, an antigene nucleic acid, a phosphorothioate oligodeoxynucleotide, and an alteration, deletion, mismatch, transition, transversion, mutation, conservative substitution, and homolog of a sequence. The phrase "at least a portion of," and "all or part of," as used herein, means that the entire gene need not be represented by the sequence so long as the portion of the gene represented is effective to block or exhibit, depending on the type of sequence used, gene expression. The sequences may be incorporated into an expression vector such as, and not limited to, a plasmid, phagemid, cosmid, yeast artificial chromosome (YAC), virus (e.g., adenovirus, vaccinia virus, retrovirus),

and defective virus (also known as a "helper virus"). The nucleotide sequence may also be administered naked, that is without an expression vector.

"Cell" and "host cell" refer to prokaryotic cells and eukaryotic cells, including plant cells, animal cells, cells of unicellular organisms, cells of multicellular
5 organisms, etc. Especially preferred are animal cells, more preferably mammalian cells and most especially human cells, including but not limited to living cells, tissues, and organs. Eukaryotic cells are cells of higher organisms in which genetic material is enclosed by a nuclear membrane. Prokaryotic cells are cells of lower organisms that
10 lack a well defined nucleus and contain genetic material that is not enclosed within a membrane of its own. The cells may be present *in vivo* or *in vitro* (e.g. in cell culture).

The invention has wide applications for effecting (obtaining, promoting, facilitating or enhancing) and/or increasing the efficiency of, intracellular delivery (e.g., transfection) and/or, in the case of nucleotides, gene expression in both *in vitro*
15 and *in vivo* applications, and is particularly useful for prokaryotic and eukaryotic animal cells, particularly mammalian cells. Intracellular delivery includes delivery into the cells through a cell membrane (plasma membrane), cell wall, and/or nuclear membrane.

The phrase "cell membrane" (also termed "plasma membrane") is used
20 in its conventional sense as denoting the outer layer or boundary of the cytoplasm of a living cell. Cell membranes are typically comprised of protein and lipids, and are generally found in animal cells.

The phrase "cell wall" is also used in its conventional sense to denote a
25 rigid or semi-rigid outer covering surrounding the protoplasts of plant cells and most prokaryotes. Cell walls are typically found, for example, in cells of bacteria, plants, algae, and fungi. Cell walls are, on the other hand, generally not present in animal cells. In plants, the wall typically comprises several layers; a primary wall composed of cellulose microfibrils running through a matrix of hemicelluloses and pectic
30 substances surrounded by a secondary wall composed of cellulose which is generally lignified to a varying extent. Cell walls of fungi may contain varying amounts of chitin. Cell walls of prokaryotes are typically strengthened by mucopeptides and may be surrounded by a mucilagenous capsule.

A wide variety of compounds can comprise the compounds to be delivered to the cells in accordance with the invention, including bioactive agents, diagnostic agents, pharmaceutical agents, and the like, and include proteins, DNA and RNA (both single and double-stranded), anti-sense and gene constructs, as well as
5 other organic or inorganic compounds. Whole genes, multiple gene sequences, and gene fragments may be utilized as well as whole chromosomes and chromosome fragments.

As noted above, the methods of the present invention may, for example, be carried out in the presence of an organic halide, with or without the application of
10 ultrasound, or in the absence of an organic halide but with the application of ultrasound. Where bioactive agents other than nucleotides are employed as the compound to be delivered, generally, for best results, an organic halide is used, although use of an organic halide in such a situation is not required.

If desired, the composition may further comprise a carrier. The carrier
15 employed may comprise a wide variety of materials. Carriers may include, for example, lipids, polymers, proteins, surfactants, inorganic compounds, metal ions, and the like, alone or in combination with water and/or a solvent, or the carrier may simply comprise water and/or a solvent. The lipids, proteins, and polymers, for example, may be in liquid form or solid form (such as, for example, the form of
20 particles, fibers, sheets, layers, etc.), or may take the form of a vesicle or other stable, organized form, which may include but is not limited to, such forms commonly referred to as, for example, liposomes, micelles, bubbles, microbubbles, microspheres, lipid-, polymer-, and/or protein-coated bubbles, microbubbles and/or microspheres, microballoons, aerogels, hydrogels, clathrates, hexagonal HII phase structures, and the
25 like. The internal void of the vesicle or other stable form may, for example, be filled with a liquid (including, for example, a gaseous precursor), a gas, a solid, or solute material, or any combination thereof, including, for example, the compound to be delivered, the organic halide, and/or any targeting ligand, as desired. Typically, the carrier is provided as an aqueous milieu, such as water, saline (such as phosphate
30 buffered saline), and the like, with or without other carrier components, although other non-aqueous solvents may also be employed, if desired. The carrier may comprise a mixture in the form of an emulsion, suspension, dispersion, solution, and the like.

Lipid (including oil) in water emulsions are especially preferred. As indicated above, the carrier may also include buffers.

Thus, "vesicle", as used herein, refers to an entity which is generally characterized by the presence of one or more walls or membranes which form one or
5 more internal voids. Vesicles may be formulated, for example, from stabilizing compounds, such as a lipid, including the various lipids described herein, a polymer, including the various polymers described herein, or a protein, including the various proteins described herein, as well as using other materials that will be readily apparent to one skilled in the art. Other suitable materials include, for example, any of a wide
10 variety of surfactants, inorganic compounds, and other compounds as will be readily apparent to one skilled in the art. Also, as will be apparent to one skilled in the art upon reading the present disclosure, the organic halides may themselves act as suitable carriers, and may in certain embodiments themselves form vesicles and other organized structures. Thus the use of the organic halides of the invention in combination with a
15 compound to be delivered, without an additional compound to serve as a carrier, is within the scope of the invention. The lipids, polymers, proteins, surfactants, inorganic compounds, and/or other compounds may be natural, synthetic or semi-synthetic. Preferred vesicles are those which comprise walls or membranes formulated from lipids. The walls or membranes may be concentric or otherwise. In the
20 preferred vesicles, the stabilizing compounds may be in the form of a monolayer or bilayer, and the mono- or bilayer stabilizing compounds may be used to form one or more mono- or bilayers. In the case of more than one mono- or bilayer, the mono- or bilayers may be concentric, if desired. Stabilizing compounds may be used to form unilamellar vesicles (comprised of one monolayer or bilayer), oligolamellar vesicles
25 (comprised of about two or about three monolayers or bilayers) or multilamellar vesicles (comprised of more than about three monolayers or bilayers). The walls or membranes of vesicles prepared from lipids, polymers or proteins may be substantially solid (uniform), or they may be porous or semi-porous. The vesicles described herein include such entities commonly referred to as, for example, liposomes, micelles,
30 bubbles, microbubbles, microspheres, lipid-, protein-and/or polymer-coated bubbles, microbubbles and/or microspheres, microballoons, microcapsules, aerogels, clathrate

bound vesicles, hexagonal H II phase structures, and the like. The vesicles may also comprise a targeting ligand, if desired.

"Lipid vesicle", "polymer vesicle" and "protein vesicle" refer respectively to vesicles formulated from one or more lipids, polymers and proteins.

5 "Liposome" refers to a generally spherical or spheroidal cluster or aggregate of amphipathic compounds, including lipid compounds, typically in the form of one or more concentric layers, for example, monolayers or bilayers. They may also be referred to herein as lipid vesicles. The liposomes may be formulated, for example, from ionic lipids and/or non-ionic lipids. Liposomes which are formulated from non-
10 ionic lipids may also be referred to as "niosomes."

"Micelle" refers to colloidal entities formulated from lipids. In certain preferred embodiments, the micelles comprise a monolayer or hexagonal H2 phase configuration. In other preferred embodiments, the micelles may comprise a bilayer configuration.

15 "Aerogel" refers to generally spherical or spheroidal entities which are characterized by a plurality of small internal voids. The aerogels may be formulated from synthetic or semisynthetic materials (for example, a foam prepared from baking resorcinol and formaldehyde), as well as natural materials, such as polysaccharides or proteins.

20 "Clathrate" refers to a solid, semi-porous or porous particle which may be associated with vesicles. In preferred form, the clathrates may form a cage-like structure containing cavities which comprise the vesicles. One or more vesicles may be bound to the clathrate. A stabilizing material may, if desired, be associated with the clathrate to promote the association of the vesicle with the clathrate. Suitable
25 materials from which clathrates may be formulated include, for example, porous apatites, such as calcium hydroxyapatite, and precipitates of polymers and metal ions, such as alginic acid precipitated with calcium salts.

"Emulsion" refers to a mixture of two or more generally immiscible liquids and is generally in the form of a colloid. The liquids may be homogeneously
30 or heterogeneously dispersed throughout the emulsion. Alternatively, the liquids may be aggregated in the form of, for example, clusters or layers, including mono- or bilayers.

"Suspension" or "dispersion" refers to a mixture, preferably finely divided, of two or more phases (solid, liquid or gas), such as, for example, liquid in liquid, solid in liquid, liquid in gas, etc.) which can preferably remain stable for extended periods of time.

5 "Hexagonal H II phase structure" refers to a generally tubular aggregation of lipids, proteins, or polymers (especially lipids) in liquid media, for example, aqueous media, in which any hydrophilic portion(s) generally face inwardly in association with an aqueous liquid environment inside the tube. The hydrophobic portion(s) generally radiate outwardly and the complex assumes the shape of a
10 hexagonal tube. A plurality of tubes is generally packed together in the hexagonal phase structure.

"Biocompatible" refers to materials which are generally not injurious to biological functions and which will not result in any degree of unacceptable toxicity, including allergenic responses and disease states. The compositions of the present
15 invention and/or components thereof are typically biocompatible.

The nucleotide sequence or other compound to be delivered may be administered, if desired, "in combination with" an organic halide, and may further be administered, if desired, "in combination with" a carrier, including a vesicle (or other stable form). "In combination with" refers to the co-administration of the compound
20 to be delivered and the organic halide (and/or carrier, if desired). The compound to be delivered and the organic halide (and/or any carrier) may be combined in any of a variety of different fashions, including simply being placed in admixture with one another. In addition, for example, the nucleotide or other compound to be delivered and/or the organic halide may be embedded, encapsulated, or attached to, or with, one
25 another, as desired (including any and all combinations thereof). The phrase "in admixture" includes solutions, suspensions, emulsions, dispersions, mixtures, etc. The phrase "attached to" or variations thereof, as used herein, denotes being linked in some manner, such as through a covalent or ionic bond or other means of chemical or electrochemical linkage or interaction. The phrase "encapsulated" and variations
30 thereof as used herein refers to a location inside an internal void of a vesicle or other structure. The phrase "embedded within" or variations thereof as used herein signifies a positioning within the wall of a vesicle or other structure. Thus, a nucleotide

sequence, for example, can be positioned variably, such as, for example, entrapped within the internal void of the vesicle, situated on the internal wall of the vesicle, incorporated onto the external surface of the vesicle, and/or enmeshed within the vesicle structure itself. In addition, one or more vesicles may be administered as a
5 cavitator. In such case, the vesicles accompany the administration of a compound and may serve to enhance the efficiency of ultrasound.

Lipids may be used in the present invention as a carrier. The lipids may be natural, synthetic or semisynthetic (i.e., modified natural). Lipids useful in the invention include, and are not limited to, fatty acids, lysolipids, oils (including
10 safflower, soybean and peanut oil), phosphatidylcholine with both saturated and unsaturated lipids including phosphatidylcholine; dioleoylphosphatidylcholine; dimyristoylphosphatidylcholine; dipentadecanoylphosphatidylcholine, dilauroylphosphatidylcholine, dioleoylphosphatidylcholine, dipalmitoylphosphatidylcholine; distearoylphosphatidylcholine;
15 phosphatidylethanolamines such as dioleoylphosphatidylethanolamine; phosphatidylserine; phosphatidylglycerol; phosphatidylinositol, sphingolipids such as sphingomyelin; glycolipids such as ganglioside GM1 and GM2; glucolipids; sulfatides; glycosphingolipids; phosphatidic acid; palmitic acid; stearic acid; arachidonic acid; oleic acid; lipids bearing polymers such as polyethyleneglycol, chitin, hyaluronic acid
20 or polyvinylpyrrolidone; lipids bearing sulfonated mono-, di-, oligo- or polysaccharides; cholesterol, cholesterol sulfate and cholesterol hemisuccinate; tocopherol hemisuccinate, lipids with ether and ester-linked fatty acids, polymerized lipids (a wide variety of which are known in the art), diacetyl phosphate, stearylamine, cardiolipin, phospholipids with short chain fatty acids of about 6 to about 8 carbons in
25 length, synthetic phospholipids with asymmetric acyl chains (e.g., with one acyl chain of about 6 carbons and another acyl chain of about 12 carbons),
6-(5-cholesten-3 β -yloxy)-1-thio- β -D-galactopyranoside, digalactosyldiglyceride,
6-(5-cholesten-3 β -yloxy)hexyl-6-amino-6-deoxy-1-thio- β -D-galactopyranoside,
6-(5-cholesten-3 β -yloxy)hexyl-6-amino-6-deoxyl-1-thio- α -D-mannopyranoside,
30 12-(((7'-diethylamino-coumarin-3-yl)carbonyl)methylamino)-octadecanoic acid;
N-[12-(((7'-diethylaminocoumarin-3-yl)carbonyl)methyl-amino)

octadecanoyl]-2-aminopalmitic acid; (cholesteryl)4'-trimethyl-ammonio)butanoate; N-succinyldioleoylphosphatidylethanolamine; 1,2-dioleoyl-sn-glycerol; 1,2-dipalmitoyl-sn-3-succinyl-glycerol; 1,3-dipalmitoyl-2-succinylglycerol; 1-hexadecyl-2-palmitoyl-glycerophosphoethanolamine and palmitoylhomocysteine, and/or combinations thereof. Vesicles or other structures may be formed of the lipids, either as monolayers, bilayers, or multilayers and may or may not have a further coating.

The preferred lipid carrier may be in the form of a monolayer or bilayer, and the mono- or bilayer may be used to form one or more mono- or bilayers. In the case of more than one mono- or bilayer, the mono- or bilayers may be concentric. The carrier may form a unilamellar vesicle (comprised of one monolayer or bilayer), an oligolamellar vesicle (comprised of about two or about three monolayers or bilayers) or a multilamellar vesicle (comprised of more than about three monolayers or bilayers). The walls or membranes of a vesicle may be substantially solid (uniform), or they may be porous or semi-porous.

Lipids bearing hydrophilic polymers such as polyethyleneglycol (PEG), including and not limited to PEG 2,000 MW, 5,000 MW, and PEG 8,000 MW, are particularly useful for improving the stability and size distribution of organic halide-containing composition. Dipalmitoylphosphatidylcholine (DPPC) may be useful in the present invention at about 70% to about 90%, dipalmitoylphosphatidylethanolamine-polyethylene glycol 5000 (DPPE-PEG 5000) may be useful at about 0% to about 20% and dipalmitoylphosphatidic acid (DPPA) may be useful at about 0% to about 20% (all percentages being in mole percent molecular weight). A preferred product which is highly useful as a carrier in the present invention contains about 82 mole percent DPPC, about 8 mole percent DPPE-PEG 5,000 MW and about 10 mole percent DPPA. Various different mole ratios of PEGylated lipid are also useful.

Additionally lipid moieties capable of polymerization are embraced in the invention as coatings for the vesicles. Examples of these include, but are not limited to, alkenyl and alkynyl moieties, such as oleyl and linoleyl groups, diacetylene, acryloyl and methacryloyl groups with or without polar groups to enhance water solubility, cyanoacrylate esters optionally carrying lipophilic esterifying groups or the compounds illustrated as A and B, below. A number of such compounds are

described, for example, in Klaveness et al., U.S. Patent No. 5,536,490. The disclosures of Klaveness et al., U.S. Patent No. 5,536,490, are hereby incorporated herein by reference in their entirety.

Fluorinated or perfluorinated lipids may also be used in this invention, either as the organic halide component or as an additional carrier material. Examples of suitable fluorinated lipids include but are not limited to compounds of the formula

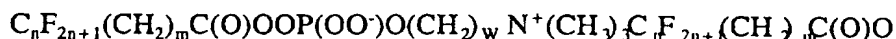

wherein: m is 0 to about 18, n is 1 to about 12; and w is 1 to about 8. Examples of and methods for the synthesis of these, as well as other fluorinated lipids useful in the present invention, are set forth in U.S. application Serial No. 08/465,868, filed June 6, 1995, Reiss et al. U.S. Patent No. 5,344,930, Frezard, F., et al., *Biochem Biophys Acta* **1994**, *1192*:61-70, and Frezard, F., et al., *Art. Cells Blood Subs and Immob Biotech.* **1994**, *22*:1403-1408, the disclosures of each of which are incorporated herein by reference in their entirety. One specific example of a difluoroacyl glycerylphosphatidylcholine, nonafluorinated diacyl glycerylphosphatidylcholine, is represented by compound A, below. Those skilled in the art will appreciate that analogous fluorinated derivatives of other common phospholipids (diacylphosphatidyl serine, diacylphosphatidyl ethanolamine, diacylphosphatidyl glycerol, diacylphosphatidyl glycerol, etc.) as well as fluorinated derivatives of fatty acyl esters and free fatty acids may also function in accordance with the scope of the invention. Additionally lipid based and fluorinated (including perfluorinated) surfactants such as may be used as carriers in the present invention.

A wide variety of such fluorinated compounds may be employed, including, for example, the class of compounds which are commercially available as ZONYL® fluorosurfactants (the DuPont Company, Wilmington, DE), including the ZONYL® phosphate salts and ZONYL® sulfate salts, which are fluorosurfactants having terminal phosphate or sulfate groups. Representative compounds are disclosed, for example, in U.S. Patent No. 5,276,145, the disclosures of which are hereby incorporated herein by reference in their entirety. Suitable ZONYL® surfactants also include, for example, ZONYL® surfactants identified as Telomer B, including Telomer

N

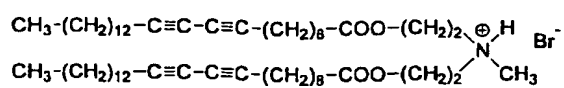

O

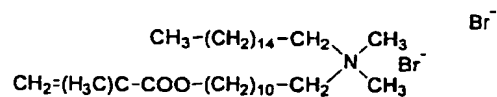

P

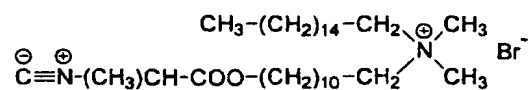

Q

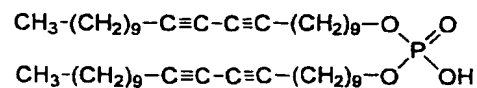

R

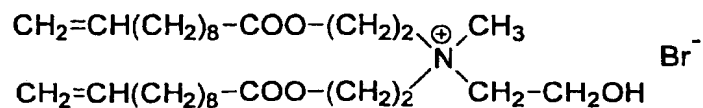

S

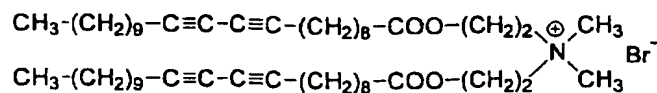

T

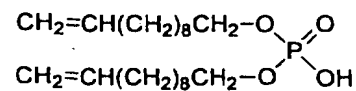

dioctadecylamidoglycyl spermidine (DOGS), N-[1-(2,3-dioleoyloxy)propyl]-N-[1-(2-
 hydroxyethyl)]-N,N-dimethylammonium iodide (DOHME), Lipofectin (DOTMA +
 DOPE, Life Technologies, Inc., Gaithersburg, MD), Lipofectamine (DOSPA +
 DOPE, Life Technologies, Inc., Gaithersburg, MD), Transfectace (Life Technologies,
 5 Inc., Gaithersburg, MD), Transfectam (Promega Ltd., Madison, WI), Cytofectin (Life
 Technologies Inc., Gaithersburg, MD). Other representative cationic lipids include but
 are not limited to phosphatidylethanolamine, phosphatidylcholine,
 glycerol-3-ethylphosphatidylcholine and fatty acyl esters thereof, di- and trimethyl
 ammonium propane, di- and tri-ethylammonium propane and fatty acyl esters thereof.
 10 A preferred derivative from this group is N-[1-(2,3-dioleoyloxy)propyl]-N,N,N-
 trimethylammonium chloride (DOTMA). Additionally, a wide array of synthetic
 cationic lipids function as compounds useful in the invention. These include common
 natural lipids derivatized to contain one or more basic functional groups. Examples of
 lipids which may be so modified include but are not limited to
 15 dimethyldioctadecylammonium bromide, sphingolipids, sphingomyelin, lysolipids,
 glycolipids such as ganglioside GM1, sulfatides, glycosphingolipids, cholesterol and
 cholesterol esters and salts, N-succinyldioleoylphosphatidylethanolamine,
 1,2,-dioleoyl-sn-glycerol, 1,3-dipalmitoyl-2-succinylglycerol,
 1,2-dipalmitoyl-sn-3-succinylglycerol, 1-hexadecyl-2-palmitoylglycerophosphatidyl-
 20 ethanolamine and palmitoylhomocysteine.

Other synthesized cationic lipids that are useful in the present invention
 are those disclosed in pending U.S. patent application Serial No. 08/391,938, filed
 February 2, 1995, and include, for example, N,N'-Bis
 (dodecylaminocarbonylmethylene)-N,N'-bis((-N,N,N-trimethylammoniummethyl-
 25 aminocarbonylmethylene)ethylenediamine tetraiodide; N,N''-Bis
 (hexadecylaminocarbonylmethylene)-N,N',N''-tris((-N,N,N-trimethylammonium-
 ethylaminocarbonylmethylenedi-ethylenetriamine hexaiodide; N,N'-Bis
 (dodecylaminocarbonylmethylene)-N,N''-bis((-N,N,N-trimethylammoniummethylamino-
 carbonylmethylene)cyclohexylene-1,4-diamine tetraiodide; 1,1,7,7-tetra((-N,N,N,N-
 30 tetramethylammoniummethylaminocarbonylmethylene)-3-hexadecyl-
 aminocarbonyl-methylene-1,3,7-triazaheptane heptaoidide; and
 N,N,N'N'-tetra((-N,N,N-trimethylammoniummethylaminocarbonylmethylene)-N'-(1,2-di

oleoylglycero-3-phosphoethanolaminocarbonylmethylene) diethylenetriamine tetraiodide. Those of skill in the art will recognize that countless other natural and synthetic variants carrying positive charged moieties will also function in the invention.

Also useful as carriers in the present invention are a wide variety of
5 surfactants (i.e., surface-active agents), including polyoxyalkylene fatty acid esters (such as polyoxyethylene fatty acid esters), polyoxyalkylene fatty alcohols (such as polyoxyethylene fatty alcohols), polyoxyalkylene fatty alcohol ethers (such as polyoxyethylene fatty alcohol ethers), polyoxyalkylene sorbitan fatty esters (such as, for example, the class of compounds referred to as TWEEN™, commercially available
10 from ICI Americas, Inc., Wilmington, DE), including poly(oxyethylene)poly(oxypropylene) copolymers (such as Pluronic), polysorbates (such as Tween20, Tween40, and Tween80), polyoxyethylene alcohols (such as Brij), and plasmalogens, the term applied to a number of a group of phospholipids present in platelets that liberate higher fatty aldehydes, e.g. palmital, on hydrolysis and may be
15 related to the specialized function of platelets in blood coagulation and plasmalogens are also present in cell membranes of muscle and the myelin sheath of nerve fibers.

In the preferred embodiment of the invention the organic halide is incorporated into the core of a vesicle which vesicle carrier is also used to complex the compound to be delivered, such as DNA.

20 A wide variety of oils may be preferably employed as carriers in the present invention including, but not limited to, safflower, soybean, and peanut oil. The composition may take the form of an oil in water emulsion if desired.

The most preferred carrier is a cationic lipid (including a cationic liposome), particularly as employed in an aqueous milieu. A preferred cationic lipid is
25 DPEPC in admixture with the neutral fusogenic lipid dioleoylphosphatidylethanolamine (DOPE). A preferred ratio of lipid to organic halide is 5:1 w/w. A preferred embodiment is to formulate the lipid or polymer as an organic halide-filled microsphere, such as a microsphere formed with the lipids dipalmitoylphosphatidylcholine (DPPC), dipalmitoylphosphatidylethanolamine coupled
30 to polyethylene glycol 5000 (DPPE-PEG5000), and dipalmitoylphosphatidic acid (DPPA). DPPC:DPPE-PEG5000:DPPA may be combined in a ratio of about 82%:8%:10% (mole %) or 83%:8%:5%. DPPE-PEG5000 is comprised of DPPE and

PEG5000 in a ratio of about 20%:80% (weight %). PEG5000 refers to PEG having an average molecular weight of about 5000.

Proteins (including peptides) useful as carriers in accordance with the present invention include molecules comprising, and preferably consisting essentially of, α -amino acids in peptide linkages. A wide variety of proteins may be employed as carriers in the present invention, including natural, synthetic, or semi-synthetic proteins. Included within the term "protein" are globular proteins, such as albumins, globulins and histones, and fibrous proteins such as collagens, elastins and keratins. Also included are "compound proteins", wherein a protein molecule is united with a nonprotein molecule, such as nucleoproteins, mucoproteins, lipoproteins, and metalloproteins. Preferable proteinaceous macromolecules include for example, albumin, collagen, polyarginine, polylysine, polyhistidine, γ -globulin and β -globulin, with albumin, polyarginine, polylysine, and polyhistidine being more preferred. Fluorinated peptides and synthetic pseudopeptides are also useful as carriers. Fluorinated peptides useful in the present invention include those described in Lohrmann, U.S. Patent No. 5,562,892, the disclosures of which are hereby incorporated herein by reference in their entirety. Cationic peptides may also be usefully employed as carriers in the present invention. Various peptides suitable for use in the present invention will be apparent to one skilled in the art based on the present disclosure.

The methods of the present invention may also involve vesicles or other organized stable form formulated from proteins, peptides and/or derivatives thereof. Vesicles which are formulated from proteins and which would be suitable for use in the methods of the present invention are described, for example, in Feinstein, U.S. Patent Nos. 4,572,203, 4,718,433, and 4,774,958, and Cerny et al., U.S. Patent No. 4,957,656, all of the disclosures of each of which are hereby incorporated by reference in their entirety. Other protein-based vesicles, in addition to those described in the aforementioned patents, would be apparent to one of ordinary skill in the art, once armed with the present disclosure.

Included among the methods described in the aforementioned patents for the preparation of protein-based vesicles are methods which involve sonicating a solution of a protein. In preferred form, the starting material may be an aqueous

solution of a heat-denaturable, water-soluble biocompatible protein. The encapsulating protein is preferably heat-sensitive so that it can be partially insolubilized by heating during sonication. Suitable heat-sensitive proteins include, for example, albumin, hemoglobin, collagen, and the like. Preferably, the protein is a human protein, with human serum albumin (HSA) being more preferred. HSA is available commercially as a sterile 5% aqueous solution, which is suitable for use in the preparation of protein-based vesicles. Of course, as would be apparent to one of ordinary skill in the art, other concentrations of albumin, as well as other proteins which are heat-denaturable, can be used to prepare the vesicles. Generally speaking, the concentration of HSA can vary and may range from about 0.1 to about 25% by weight, and all combinations and subcombinations of ranges therein. It may be preferable, in connection with certain methods for the preparation of protein-based vesicles, to utilize the protein in the form of a dilute aqueous solution. For albumin, it may be preferred to utilize an aqueous solution containing from about 0.5 to about 7.5% by weight albumin, with concentrations of less than about 5% by weight being preferred, for example, from about 0.5 to about 3% by weight.

The protein-based vesicles may be prepared using equipment which is commercially available. For example, in connection with a feed preparation operation as disclosed, for example, in Cerny, et al., U.S. Patent No. 4,957,656, stainless steel tanks which are commercially available from Walker Stainless Equipment Co. (New Lisbon, WI), and process filters which are commercially available from Millipore (Bedford, MA), may be utilized.

The sonication operation may utilize both a heat exchanger and a flow through sonicating vessel, in series. Heat exchanger equipment of this type may be obtained from ITT Standard (Buffalo, NY). The heat exchanger maintains operating temperature for the sonication process, with temperature controls ranging from about 65°C to about 80°C, depending on the makeup of the media. The vibration frequency of the sonication equipment may vary over a wide range, for example, from about 5 to about 40 kilohertz (kHz), with a majority of the commercially available sonicators operating at about 10 or 20 kHz. Suitable sonicating equipment include, for example, a Sonics & Materials Vibra-Cell, equipped with a flat-tipped sonicator horn, commercially available from Sonics & Materials, Inc. (Danbury, CT). The power

applied to the sonicator horn can be varied over power settings scaled from 1 to 10 by the manufacturer, as with Sonics & Materials Vibra-Cell Model VL1500. An intermediate power setting, for example, from 5 to 9, can be used. It is preferred that the vibrational frequency and the power supplied be sufficient to produce cavitation in the liquid being sonicated. Feed flow rates may range from about 50 mL/min to about 1000 mL/min, and all combinations and subcombinations of ranges therein. Residence times in the sonication vessel can range from about 1 second to about 4 minutes, and gaseous fluid addition rates may range from about 10 cubic centimeters (cc) per minute to about 100 cc/min, or 5% to 25% of the feed flow rate, and all combinations and subcombinations of ranges therein.

It may be preferable to carry out the sonication in such a manner to produce foaming, and especially intense foaming, of the solution. Generally speaking, intense foaming and aerosolating are important for obtaining a contrast agent having enhanced concentration and stability. To promote foaming, the power input to the sonicator horn may be increased, and the process may be operated under mild pressure, for example, about 1 to about 5 psi. Foaming may be easily detected by the cloudy appearance of the solution, and by the foam produced.

Such sonication methods may also be employed to prepare lipid-based or other types of carriers as will be apparent to the skilled artisan.

Suitable methods for the preparation of protein-based vesicles may involve physically or chemically altering the protein or protein derivative in aqueous solution to denature or fix the material. For example, protein-based vesicles may be prepared from a 5% aqueous solution of HSA by heating after formation or during formation of the contrast agent via sonication. Chemical alteration may involve chemically denaturing or fixing by binding the protein with a difunctional aldehyde, such as glutaraldehyde. For example, the vesicles may be reacted with 0.25 grams of 50% aqueous glutaraldehyde per gram of protein at pH 4.5 for 6 hours. The unreacted glutaraldehyde may then be washed away from the protein.

The carriers may also be formulated with polymers, natural, synthetic, or semisynthetic. A wide variety of polymers may be utilized as carriers in the present invention, including synthetic polymers including polyethylenes (such as, for example, polyethylene glycol), polyoxyethylenes (such as, for example, polyoxyethylene glycol),

polypropylenes (such as, for example, polypropylene glycol), pluronic acids and alcohols, polyvinyls (such as, for example, polyvinyl alcohol), and polyvinylpyrrolidone. Exemplary natural polymers suitable for use in the present invention include polysaccharides. Polysaccharides include, for example, arabinans, 5 fructans, fucans, galactans, galacturonans, glucans, mannans, xylans (such as, for example, inulin), levan, fucoidan, carrageenan, galactocarolose, pectin (including high methoxy pectin and low methoxy pectin; with low methoxy pectin denoting pectin in which less than 40% of the carboxylic acid groups are esterified and/or amidated, and high methoxy pectin denoting pectin in which 40% or more of the carboxylic acid 10 groups are esterified and/or amidated), pectic acid, amylose, pullulan, glycogen, amylopectin, cellulose, carboxymethylcellulose, hydroxypropyl methylcellulose, dextran, pustulan, chitin, agarose, keratan, chondroitin, dermatan, hyaluronic acid and alginic acid, and various other homopolymers or heteropolymers such as those containing one or more of the following aldoses, ketoses, acids or amines: erythrose, 15 threose, ribose, arabinose, xylose, lyxose, allose, altrose, glucose, mannose, gulose, idose, galactose, talose, erythrulose, ribulose, xylulose, psicose, fructose, sorbose, tagatose, glucuronic acid, gluconic acid, glucaric acid, galacturonic acid, mannuronic acid, guluronic acid, glucosamine, galactosamine and neuraminic acid. It is recognized that some polymers may be prepared by chemically modifying naturally occurring 20 polymers. Such chemically modified natural polymers also referred to as semisynthetic polymers. The polymers employed may also comprise fluorinated polymers, including those described in Lohrmann, U.S. Patent No. 5,562,892, the disclosures of which are hereby incorporated herein by reference in their entirety. Furthermore, the polymers may be in the form of vesicles, such as for example, those described in Unger, U.S. 25 Patent No. 5,205,290, the disclosures of which are hereby incorporated herein by reference in their entirety. As used herein, the term "polymer" denotes molecules formed from the chemical union of two or more repeating units, and include dimers, trimers, and oligomers. In preferred form, the term "polymer" refers to molecules which comprise 10 or more repeating units.

30 Metal ions may also be employed as carriers in the present invention. Suitable metal ions include calcium ions, magnesium ions, zinc ions, and the like, as well as a wide variety of inorganic compounds. Other suitable metal ions as well as

other suitable inorganic compounds will be readily apparent to those skilled in the art once armed with the present invention.

Other useful agents that may be employed in the carrier of the present invention include osmotic agents, anti-microbials, viscosity raising agents, suspending
5 agents, humectants and anti-humectants, depending upon the particular formulation desired.

One or more emulsifying or stabilizing agents may also be employed as or be included in the carrier. These agents help to maintain the size of any discrete units (e.g., liquid droplets, particles, gas bubbles, etc.) of the organic halide and/or
10 compounds to be delivered that may have formed the composition. The size of these discrete units will generally affect the size of any resultant gas bubbles that may form from any gaseous precursors. The emulsifying and stabilizing agents also may be used to generally coat or stabilize the organic halides, compounds to be delivered, etc. Stabilization is desirable to maximize the intracellular delivery effect. Although
15 stabilization is preferred, this is not an absolute requirement. Because any gas resulting from organic halide gaseous precursors is more stable than air, they may still be designed to provide useful delivery means; for example, they pass through the pulmonary circulation following peripheral venous injection, even when not specifically stabilized by one or more coating or emulsifying agents. One or more coating or
20 stabilizing agents is preferred however, as are flexible stabilizing materials. Also, it should be noted that compositions stabilized by polysaccharides, gangliosides, and polymers are generally more effective than those stabilized by albumin and other proteins. Also, liposomes prepared using aliphatic compounds are preferred, since microspheres stabilized with these compounds are much more flexible and stable to
25 pressure changes.

The carrier of the invention may also comprise a wide variety of viscosity modifiers, including and not limited to carbohydrates and their phosphorylated and sulfonated derivatives; polyethers, preferably with molecular weight ranges between 400 and 8000; di- and trihydroxy alkanes and their polymers, preferably with
30 molecular weight ranges between 800 and 8000. Glycerol propylene glycol, polyethylene glycol, polyvinyl pyrrolidone, and polyvinyl alcohol may also be useful as carriers or stabilizers in the present invention. Particles which are porous or

semi-solid such as hydroxyapatite, metal oxides and coprecipitates of gels, e.g., hyaluronic acid with calcium may be used and may formulate a center or nidus to stabilize compositions of the invention.

Emulsifying and/or solubilizing agents may also be used in a carrier,
5 particularly in conjunction with lipids or liposomes. Such agents include and are not limited to, acacia, cholesterol, diethanolamine, glyceryl monostearate, lanolin alcohols, lecithin, mono- and di-glycerides, mono-ethanolamine, oleic acid, oleyl alcohol, poloxamer, polyoxyethylene 50 stearate, polyoxyl 35 castor oil, polyoxyl 10 oleyl ether, polyoxyl 20 cetostearyl ether, polyoxyl 40 stearate, polysorbate 20, polysorbate
10 40, polysorbate 60, polysorbate 80, propylene glycol diacetate, propylene glycol monostearate, sodium lauryl sulfate, sodium stearate, sorbitan, sorbitan mono-laurate, sorbitan mono-oleate, sorbitan mono-palmitate, sorbitan monostearate, stearic acid, trolamine, and emulsifying wax. All lipids with perfluoro fatty acids as a component of the lipid in lieu of the saturated or unsaturated hydrocarbon fatty acids found in
15 lipids of plant or animal origin may be used. Suspending and/or viscosity-increasing agents that may be particularly useful with lipid or liposome solutions include but are not limited to, acacia, agar, alginic acid, aluminum mono-stearate, bentonite, magma, carbomer 934P, carboxymethylcellulose, calcium and sodium and sodium 12, glycerol, carrageenan, cellulose, dextrin, gelatin, guar gum, hydroxyethyl cellulose,
20 hydroxypropyl methylcellulose, magnesium aluminum silicate, methylcellulose, pectin, polyethylene oxide, polyvinyl alcohol, povidone, propylene glycol, alginate, silicon dioxide, sodium alginate, tragacanth, and xanthum gum. A preferred product of the present invention incorporates lipid as a mixed solvent system in a ratio of 8:1:1 or 9:1:1 normal saline:glycerol:propylene glycol.

25 The amount of carrier material employed in connection with the subject invention may vary, as one skilled in the art will recognize upon being placed in possession of the subject disclosure, and may be dependent on such factors as the particular carrier used, the type and nature of the compound to be delivered, the age, weight, cells or patient (animal) to be treated, the particular diagnostic, therapeutic or
30 other application intended (including the disease state, if any, to be treated), and the organic halide (if any) used. Generally, smaller amounts of carrier are employed, and increased until the desired delivery result is obtained. Representative amounts are set

forth in the examples herein. Of course, higher or lower amounts may be employed, as will be recognized by the skilled artisan.

A wide variety of different methods may be used to mix the organic halide, compound to be delivered, and/or carrier, and incorporate the compound to be delivered with or into any organic halide and/or carrier. Methods include shaking by hand, vortexing, mechanical shaking (e.g. with an Espe CapMix, Espe Medizin-Dental GMBH, Seefeld, Germany), extruder (e.g. with a Lipex Biomembranes Extruder Device, Vancouver, B.C., Canada), microemulsification (e.g. with a Microfluidizer, Microfluidics Corp., Newton, MA), mixing with static in line mixers (Cole-Parmer Instrument Co., Vernon Hills, IL), spray drying (e.g. with a Buechi spray dryer, Brinkmann Ind., Inc., Westbury, MA), mechanical stirring/mixing (e.g. with a Silverson Mixer, Silverson Machines, Ltd., Waterside Chesham Bucks, England) and sonication. In general it is desirable to mix the carrier (e.g. lipids such as DPEPC and DOPE) together with the organic halide prior to adding the compound to be delivered (e.g., DNA). After adding the DNA, a carrier and organic halide association will form with the DNA. If desired, additional mixing may then be performed by one of the above techniques. In some other situations, e.g. calcium precipitation, the DNA, organic halide, and cations may be added together with one or more stabilizing agents to form the precipitates of DNA/carrier/organic halide in a single step process. Again, one of a variety of mixing techniques as described above may be employed to decrease the size of the resultant particles.

The carriers may be combined with the compound to be delivered and the organic halide in varying amounts and percentages, as will be understood by those skilled in the art once armed with the present disclosure. Typically, smaller amounts of all compositional components are employed, and increased selectively in increments until the desired delivery effect is achieved. Generally, when the compound to be delivered is employed with a carrier, the ratio of organic halide and any carrier to the compound to be delivered may be from about 6 to about 1, to about 1 to about 6, and variations therebetween. Preferably, the carrier to compound to be delivered ratio is about 6 to about 1. Representative ratios are provided by the examples herein. Of course, other ratios can be suitably employed over a wide variety of ranges as desired,

as will be recognized by the skilled artisan, and all such ratios are within the scope of the present invention.

The resulting composition may be stored as a lyophilized, or freeze dried, material for inhalation or hydration prior to use or as a preformed suspension.

5 Cryopreservatives known to skilled artisans once armed with the present disclosure may be used in the lyophilized form of the composition. To prevent agglutination or fusion of vesicles as a result of lyophilization, it may be useful to include additives which prevent such fusion or agglutination from occurring. Additives which may be useful include sorbitol, mannitol, sodium chloride, glucose, trehalose,
10 polyvinylpyrrolidone and poly(ethylene glycol) (PEG), for example, PEG polymers having a molecular weight of from about 400 to about 10,000, with PEG polymers having molecular weights of about 1000, 3000 (such as PEG3350) and 5000 being preferred. These and other additives are described in the literature, such as in the U.S. Pharmacopeia, USP XXII, NF XVII, The United States Pharmacopeia, The
15 National Formulary, United States Pharmacopeial Convention Inc., 12601 Twinbrook Parkway, Rockville, MD 20852, the disclosures of which are hereby incorporated herein by reference in their entirety. Lyophilized preparations generally have the advantage of greater shelf life. As noted above, if desired, the lyophilized composition may be (and preferably is) rehydrated prior to use.

20 The route of administration varies depending upon the intended application. For cell culture applications, the composition is typically contacted with the cells by, for example, adding it to the cell culture media or applying it directly to the cells. Advantages of this invention for transfection in cell culture media include high activity in serum containing media and a single step transfection process with
25 higher efficiency transfection than in other more complicated systems. Indeed, the present invention makes it possible to obtain gene expression in cells in which transfection was otherwise impossible or extremely difficult. For *in vivo* administration the composition may simply be injected, such as intravenously, intravascularly, intralymphatically, parenterally, subcutaneously, intramuscularly,
30 intranasally, intrarectally, intraperitoneally, interstitially, into the airways via nebulizer, hyperbarically, orally, topically, or intratumorally, or otherwise administered.

One or more targeting ligands may be incorporated into the carrier to facilitate uptake by selected cells. Targeting ligands include, for example, peptides, antibodies, antibody fragments, glycoproteins, carbohydrates, etc. Preferably, the targeting ligand is covalently attached to the carrier, e.g., to a lipid. Preferably the targeting ligand is attached to a linker which is attached to the surface of the carrier. Preferred linkers are polymers, for example, bifunctional PEG having a molecular weight of about 1,000 to about 10,000, most preferably 5,000. Generally, the targeting ligand is incorporated into the carrier from about 0.1 mole % to about 25 mole %, preferably about 1 mole % to about 10 mole %.

In this regard, the composition may be targeted to coated pits of selected cells and taken up into endosomes via a process of receptor mediated endocytosis. If desired ultrasound energy may be applied to the target tissue to facilitate gene expression. For inhalation the composition may be inhaled via a nebulizer or via an inhaler. Also, oral or rectal routes may be utilized to administer these composition. Transcutaneous application may be accomplished by the use of penetration enhancing agents with or without the application of sonophoresis (e.g. low frequency sound in range of 10 to 100 Khz) or iontophoresis. Also interstitial (e.g. intratumoral) and subcutaneous injection may be performed to administer the composition.

Also the invention may be practiced with gene gun techniques or electroporation, or in combination with other transfection techniques known in the art. In either case, ultrasound may be applied to the cells before, after, and/or simultaneously with the gene gun or electroporation procedure. The electric fields of electroporation may also be pulsed in tandem with the ultrasound energy to further increase the efficacy of transfection.

The compounds and compositions may, in accordance with the present invention, be administered alone, or together with ultrasound. If ultrasound is employed, it is administered at a frequency and energy level sufficient to assist in inducing the uptake of the compound to the cell. Where organic halide gaseous precursors are employed, the ultrasound may be applied at a frequency and energy level sufficient to convert the organic halide gaseous precursor to a gas. For example, the present invention of administering compounds to cells includes administering a nucleotide sequence (or other compound of interest to be delivered) to a cell and

applying ultrasound to the cell for a time effective to induce the uptake of the nucleotide sequence (or other compound). Enhanced delivery of the compound (and expression of the nucleotide sequence, in the case of nucleotide sequence being administered) results. Ultrasound is carried out at a frequency, energy level, and duty cycle for a therapeutically effective time in which to induce delivery of the nucleotide sequence. Suitable frequencies, energy levels and duty cycles are disclosed herein, and other ranges will be readily apparent to one skilled in the art once armed with the present disclosure.

The methods of the present invention permit the delivery of sequences coding for the gene expression of a variety of proteins, and antisense sequences which block gene expression of a variety of proteins. As a result, a number of diseases may be treated with the transfection methods of the present invention. In addition, the methods of transfection of the present invention may be practiced *in vivo*, *ex vivo*, and *in vitro*.

Administration of a nucleotide sequence by a microsphere utilizes a nucleotide sequence attached to a microsphere in various positions relative to the microsphere as set forth above. While not intending to be bound by any particular theory or theories of operation, the microsphere approach is believed to rely on the fusion of the nucleotide sequence containing microsphere with the plasma membrane of the host cell. The nucleotide sequence subsequently traverses the cytoplasm and enters the nucleus. The use of a microsphere results in little toxic effects to the host cell, tissue, and the patient (in the case of *in vivo* use).

Intracellular delivery and transfection in accordance with the methods of the present invention may be performed *in vivo*, *ex vivo*, and *in vitro*. Included within the above three methods is human gene therapy including wherein cells to be treated are excised from a patient. The cells are treated with an appropriate nucleotide sequence and transfection with ultrasound is carried out in cell culture. The transfected cells are analyzed for gene expression of the appropriate protein. The successfully transfected cells, measured by gene expression, are then returned to the body of the patient. Transfection with ultrasound thereby results in the treatment of diseases by gene therapy. Diseases to be treated with the methods of the present invention include and are not limited to acquired immune deficiency syndrome, autoimmune diseases,

chronic viral infection, hemophilia, muscular dystrophy, cystic fibrosis, diabetes, atherosclerosis, liver cancer, lung cancer, prostate cancer, ovarian cancer, brain cancer, kidney cancer, melanoma, neuroblastoma, and breast cancer. Many other diseases may, of course, be treated with the methods of the present invention, as will
5 be apparent to the skilled artisan upon reading the present disclosure, and the treatment of all such diseases are to be considered within the scope of the present methods.

The use of heat, for example in the form of ultrasound, lithotripsy shock waves, and increased body temperature, in the present invention is useful in aiding the delivery of compounds, such as, for example, nucleotide sequences, into cells for
10 therapeutic purposes. The introduction of a nucleotide sequence into the cell is the first step in incorporating the sequence into the genome. Such transfection techniques may be useful in conjunction with testing the range of ultrasound frequency useful in inducing the delivery of compounds, including nucleotide sequences, to cells.

Each of the methods of the present invention include administering all or
15 part of a sense or an antisense sequence for insulin (Giddings and Carnaghi, *Mol. Endocrinol.* **1990** 4:1363-1369), Bcl 2 (Tsujimoto, Y., *et al.*, *PNAS, USA* **1986**, 83:5214-5218), human leukocyte antigen (Trucco, G., *et al.*, *Diabetes* **1989**, 38:1617-1622), thymidine kinase (Axel, R., *et al.*, *J. Supramol. Struct.* **1979**, 8 (Suppl. 3):41), HLA-B7, Factor VIII (Higuchi, M., *et al.*, *Genomics* **1990**, 6:65-71, ras/p53 (Arai, N., *et al.*, *Mol Cell Biol* **1986**, 6:3232-3239, Mitsudomi, T., *et al.*, *Chest* **1993**, 104:362-365), high density lipoprotein (hdl), leutinizing hormone releasing hormone (Maier, C.C., *et al.*, *Cell Mol Neurobiol* **1992**, 12:447-454) and leutinizing hormone releasing hormone antagonist, antitumoral agents such as and not limited to insulin-like growth factor-1 (IGF-1, Barnes, M., *et al.*, *Obstetrics and Gynecology* **1997**, 89:145-
25 155), anti-IGF-1 (human IGF-1 gene fragment from published patent application GB2241703 GenBank accession number A29119), anti-k-ras (dog spleen mRNA 212 nucleotides GenBank accession number S42999), anti-c-fos (*Rattus norvegicus* Sprague Dawley c-fos gene, 5' flanking region GenBank accession number U02631), bcr-abl (Barnes, M., *et al.*, *Obstetrics and Gynecology* **1997**, 89:145-155), c-myc (mouse c-
30 myc gene, exons 1 and 2 GenBank accession number L00038, J00373, and J00374), c-myc promoter (Barnes, M., *et al.*, *Obstetrics and Gynecology* **1997**, 89:145-155), erbB-2 promoter (Barnes, M., *et al.*, *Obstetrics and Gynecology* **1997**, 89:145-155),

erbB2 promoter-cytosine deaminase (human c-erb B2/neu protein gene, partial cDNA (cds) GenBank accession number M95667), and antivirals such as and not limited to anti-human papilloma virus (HPV), anti-human immunodeficiency virus (HIV) such as HIVenv+rev (HIV type 1, isolate BTSPR, env gene, C2V3 region, partial cds

5 GenBank accession number U53195), tar/Td-rev (HIV type 1 rev-1 gene, 5' end GenBank accession number M38031, synthetic HIV1 TAR, 5' end GenBank accession number M27943), ribozyme, zeta-chimpanzee receptor, and the like, and all or part of a sequence encoding cytokines such as and not limited to interleukin 2 (IL-2) (human brain mRNA 418 nucleotides GenBank accession number S77835), interleukin 4 (Arai,

10 N., *et al.*, *J Immunol* **1989**, *142*:274-282), interleukin 7 (human gene, exon 1 GenBank accession number M29048), interleukin 12 (mouse 5' flanking region of IL-12 p35 gene GenBank accession number D63334), interleukin 4 (human IL-4 gene, complete cds GenBank accession number M23442), interleukin 6 (human gene for nuclear factor NF-IL-6 GenBank accession number X52560); gp130 (LIF receptor/IL-6 receptor

15 complex component mRNA 150 nucleotides GenBank accession number S80479), interleukin 6 receptor, granulocyte macrophage colony stimulating factor (GM-CSF) (human GM-CSF gene, 5' flanking/promoter region GenBank accession number U31279), interferon including interferon gamma (human immune IFN- γ gene, complete cds GenBank accession number J00219, M37265, V00536), tumor necrosis

20 factor beta, TNF- β , (human 5' sequence of TNF- β gene GenBank accession number X59351)), vascular endothelial growth factor (VEGF), human growth hormone (hGH, Fidders, J.C., *et al.*, *Proc Natl Acad Sci (USA)* **1979** *76*:4294-4298), colony stimulating factor, Factor VIII, Factor IX, Factor X, and the like. Other sequences useful in the methods of the present invention include ribozymes including catalytic

25 RNA which may have a hammerhead secondary structure (Bratty, *et al.*, *Biochim. Biophys. Acta* **1993** *1216*:345-349 and McKay, D.B., *RNA* **1996** *2*:395-403), c-myc, c-myb, tumor suppressor genes such as and not limited to human tumor antigen p53 (5' end GenBank accession number M26864), genes offering chemoprotection such as and not limited to those encoding multidrug resistance protein (MDR) (human *mdr1* gene

30 GenBank accession number X78081), genes for antigen overexpression such as and not limited to HLA-B7 (beta 2 microglobulin) (mouse MHC class I HLA-B7 gene, 5' flanking region GenBank accession M35971), carcinoembryonic antigen (CEA) (human

5' region GenBank accession number U17131), suicide genes such as and not limited to thymidine kinase (TK) (human TK gene encoding TK and promoter region GenBank accession number M13643), Ras, gene complementation genes such as and not limited to cystic fibrosis transmembrane conductance regulator (CFTR) (human CFTR gene, exon 1 GenBank accession number M55106 and M55499), adenosine deaminase (ADA) (human ADA gene, complete cds GenBank accession number M13792), glucocerebrosidase, IRAP/TK (human mRNA for IRAP GenBank accession number X53296), vascular endothelial growth factor (VEGF) (mus musculus VEGF gene, partial cds and promoter region GenBank accession number U41383), LDLR (human LDL receptor gene fragment GenBank accession number M60949), Fanconi Anemia Complementation Group C (FACC) (human FACC gene, 5' region GenBank accession number X83116), p47-phox (human P47 LBC oncogene mRNA, complete cds GenBank accession number U03634), Factor IX (human Factor IX gene, exon 1 GenBank accession number K02048), α -1 antitrypsin (human α -1 antitrypsin gene S variant, complete cds GenBank accession number K02212), α -1 iduronidase (human iduronidase gene sequence GenBank accession number M88001), and iduronate sulfatase (Ids) (Mus musculus Ids mRNA, complete cds GenBank accession number L07921), and gene markers such as and not limited to NeoR and LacZ, (bacteriophage T4 td gene, exon 2, 3' end; ORF2, complete cds and ORF3, 5' end GenBank accession number M22627, and cloning vector pZEO (isolate SVLacZ) β -galactosidase (lacZ) gene, phleomycin/zeocin-binding protein (ShBle) gene, (complete cds GenBank accession number L36850).

DNA encoding certain proteins may be used in the treatment of many different types of diseases. For example, adenosine deaminase may be provided to treat ADA deficiency; tumor necrosis factor and/or interleukin-2 may be provided to treat advanced cancers; HDL receptor may be provided to treat liver disease; thymidine kinase may be provided to treat ovarian cancer, brain tumors, or HIV infection; HLA-B7 may be provided to treat malignant melanoma; interleukin-2 may be provided to treat neuroblastoma, malignant melanoma, or kidney cancer; interleukin-4 may be provided to treat cancer; HIV env may be provided to treat HIV infection; antisense ras/p53 may be provided to treat lung cancer; and Factor VIII may be provided to treat Hemophilia B. See, for example, Thompson, L., *Science*, 1992, 258,

744-746. Nucleotide sequences for the above-identified proteins are available in the scientific literature, including GENBANK, and are known to skilled artisans.

In addition to a coding sequence or antisense sequence, the nucleotide sequence administered to cells may have additional sequences to assist in the expression
5 of the sequence. Suitable expression vectors, promoters, enhancers, and other expression control elements are known in the art and may be found in Sambrook et al., *Molecular Cloning: A Laboratory Manual*, second edition, Cold Spring Harbor Laboratory Press, Cold Spring Harbor, NY (1989). Promoters such as and not limited to SV40, RSV, CMV, cd5k, IL5R α pgk-1, sr α , TK, and the like are useful in the
10 present invention. Transcription and/or translation control elements may be operatively linked to the sequence. For example, in an upstream position, a promoter may be followed by a translation initiation signal, comprising a ribosome binding site and an initiation codon, and in a downstream position may be a transcription termination signal. The transcription and translation control elements may be ligated in any
15 functional combination or order. The transcription and translation control elements used in any particular embodiment of the invention will be chosen with reference to the type of cell into which the expression vector will be introduced, so that an expression system is created. The selection of promoters, enhancers, and other expression control elements and the preparation of expression vectors suitable for use in the present
20 invention will be well within the ambit of one skilled in the art once armed with the present disclosure. Also, introduction of the expression vector incorporating a sequence into a host cell can be performed in a variety of ways known in the art.

Mammalian cells may be primed to be more susceptible to uptake of DNA for gene therapy by the addition of various media, buffers, and chemicals known
25 to those of skill in the art and set forth in Sambrook, *supra*. Administration of nucleotide sequences *in vivo* may include, if desired, more than one sequence. For example, a single carrier may contain more than one sequence or carriers containing different sequences may be co-administered. In addition, one sequence may be delivered in a carrier and another naked sequence coadministered. Additional
30 sequences, such as promoter sequences, may be delivered together with a sequence for therapeutic delivery, to increase expression thereof. For example, a heat shock protein

nucleic acid sequence is an example of an upregulating gene sequence which may be used to increase expression of a second gene sequence.

A wide variety of compounds (in addition to genetic material) may also be delivered to cells in accordance with the methods of the invention. Such other
5 compounds include various other bioactive agents. As used herein, "bioactive agent" refers to any substance which may be used in connection with an application that is therapeutic or diagnostic in nature, such as, for example, in methods for diagnosing the presence or absence of a disease in a patient or in methods for the treatment of disease in a patient. As used herein, "bioactive agent" refers also to substances which are
10 capable of exerting a biological effect *in vitro*, *in vivo*, and/or *ex vivo*. The bioactive agents may be neutral, or positively or negatively charged, etc., as desired. Examples of suitable bioactive agents include diagnostic and pharmaceutical agents, including drugs, synthetic organic molecules, proteins, peptides, vitamins, steroids, steroid analogs; and also include genetic material, including nucleosides, nucleotides and
15 polynucleotides.

The phrase "diagnostic agent", as used herein, refers to any agent which may be used in connection with methods for imaging an internal region of a patient and/or diagnosing the presence or absence of a disease in a patient. Exemplary
20 diagnostic agents include, for example, contrast agents for use in connection with ultrasound imaging, magnetic resonance imaging or computed tomography imaging of a patient. Diagnostic agents may also include any other agents useful in facilitating diagnosis of a disease or other condition in a patient, whether or not imaging methodology is employed.

The terms "pharmaceutical agent" or "drug", as employed herein, refer
25 to any therapeutic or prophylactic agent which may be used in the treatment (including the prevention, diagnosis, alleviation, or cure) of a malady, affliction, disease or injury in a patient. Therapeutically useful peptides, polypeptides and polynucleotides may be included within the meaning of the term pharmaceutical or drug, as are various other therapeutically useful organic or inorganic compounds.

30 Particular examples of pharmaceutical agents which may be delivered by the methods of the present invention include, but are not limited to: mitotic inhibitors such as the vinca alkaloids, radiopharmaceuticals such as radioactive iodine, phosphorus

and cobalt isotopes; hormones such as progestins, estrogens and antiestrogens; anti-helminthics, antimalarials and antituberculosis drugs; biologicals such as immune sera, antitoxins and antivenins; rabies prophylaxis products; bacterial vaccines; viral vaccines; aminoglycosides; respiratory products such as xanthine derivatives, theophylline and
5 aminophylline; thyroid therapeutics such as iodine salts and anti-thyroid agents; cardiovascular products including chelating agents and mercurial diuretics and cardiac glycosides; glucagon; blood products such as parenteral iron, hemin, hematoporphyrins and their derivatives; targeting ligands such as peptides, antibodies, and antibody
10 tripeptide, microbial cell wall components, lymphokines (e.g. bacterial endotoxin such as lipopolysaccharide and macrophage activation factor); subunits of bacteria (such as Mycobacteria and Cornebacteria); the synthetic dipeptide N-acetyl-muramyl-L-alanyl-D-isoglutamine; antifungal agents such as ketoconazole, nystatin, griseofulvin, flucytosine (5-fc), miconazole, and amphotericin B; toxins such as ricin; immunosuppressants such
15 as cyclosporins; and antibiotics such as β -lactam and sulfazecin; hormones such as growth hormone, melanocyte stimulating hormone, estradiol, beclomethasone dipropionate, betamethasone, betamethasone acetate, betamethasone sodium phosphate, betamethasone disodium phosphate, betamethasone sodium phosphate, cortisoné acetate, dexamethasone, dexamethasone acetate, dexamethasone sodium phosphate, flunisolide,
20 hydrocortisone, hydrocortisone acetate, hydrocortisone cypionate, hydrocortisone sodium phosphate, hydrocortisone sodium succinate, methylprednisolone, methylprednisolone acetate, methylprednisolone sodium succinate, paramethasone acetate, prednisolone, prednisolone acetate, prednisolone sodium phosphate, prednisolone tebutate, prednisone, triamcinolone, triamcinolone acetonide, triamcinolone diacetate, triamcinolone
25 hexacetonide, fludrocortisone acetate, oxytocin, and vasopressin, as well as their derivatives; vitamins such as cyanocobalamin neionic acid; retinoids and derivatives such as retinol palmitate and α -tocopherol; peptides and enzymes such as manganese superoxide dismutase and alkaline phosphatase; anti-allergens such as amalexanox; anti-coagulation agents such as phenprocoumon and heparin; tissue plasminogen activators
30 (TPA), streptokinase, and urokinase; circulatory drugs such as propranolol; metabolic potentiators such as glutathione; antibiotics such as p-aminosalicylic acid, isoniazid, capreomycin sulfate cycloserine, ethambutol hydrochloride ethionamide, pyrazinamide,

rifampin, streptomycin sulfate, dapson, chloramphenicol, neomycin, ceflaxor, cefadroxil, cephalixin, cephadrine, erythromycin, clindamycin, lincomycin, amoxicillin, ampicillin, bacampicillin, carbenicillin, dicloxicillin, cyclacillin, picloxicillin, hetacillin, methicillin, nafcillin, oxacillin, penicillin (G and V), ticarcillin, rifampin and tetracycline; antivirals

5 such as acyclovir, DDI, Foscarnet, zidovudine, ribavirin and vidarabine monohydrate; antiangiinals such as diltiazem, nifedipine, verapamil, erythritol tetranitrate, isosorbide dinitrate, nitroglycerin (glyceryl trinitrate) and pentaerythritol tetranitrate; antiinflammatories such as diflusal, ibuprofen, indomethacin, meclufenamate, mefenamic acid, naproxen, oxyphenbutazone, phenylbutazone, piroxicam, sulindac, tolmetin, aspirin,

10 and salicylates; antiprotozoans such as chloroquine, hydroxychloroquine, metranidazole, quinine and meglumine antimonate; antirheumatics such as penicillamine; narcotics such as paregoric; opiates such as codeine, heroin, methadone, morphine, and opium; cardiac glycosides such as deslanoside, digitoxin, digoxin, digitalin, and digitalis; neuromuscular blockers such as atracurium nesylate, gallamine triethiodide, hexaflorenium bromide,

15 metocurine iodide, pancurium bromide, succinylcholine chloride (suxamethonium chloride), tubocurarine chloride and vecuronium bromide; sedatives such as amobarbital, amobarbital sodium, aprobarbital, butobarbital sodium, chloral hydrate, ethchlorvynol, ethinamate, flurazepam hydrochloride, glutethimide, methotrimeprazine hydrochloride, methypylon, midazolam hydrochloride, paraldehyde, pentobarbital, pentobarbital sodium,

20 secobarbital sodium, tulbutal, temazepam and triazolam; local anesthetics such as bupivacaine hydrochloride, chloroprocaine hydrochloride, etidocaine hydrochloride, lidocaine hydrochloride, mepivacaine hydrochloride, procaine hydrochloride, and tetracaine hydrochloride; general anaesthetics such as droperidol, etamine hydrochloride, methohexital sodium and thiopental sodium; antineoplastic agents such as methotrexate,

25 fluorouracil, adriamycin, mitomycin, ansamitomycin, bleomycin, cystein arabinoside, arabinosyl adenine, mercaptopolylysine, vincristine, busulfan, chlorambucil, azidothymidine, melphalan (e.g. PAM, L-PAM or phenylalanine mustard), mercaptopurine, mitotane, procarbazine hydrochloride, dactinomycin (actinomycin D), danorubicin hydrochloride, dosorubicin hydrochloride, taxol, plicamycin (mithramycin),

30 aminoglutethimide, estramustine phosphate sodium, flutamide, leuprolide acetate, leuprolide acetate, megestrol acetate, tamoxifen citrate, testolactone, trilostane, amsacrine (m-AMSA), asparaginase, etoposide (VP-16), interferon α -2a, interferon α -2b, teniposide

(VM-26), vinblastine sulfate (VLB), vincristine sulfate, hydroxyurea, procarbazine, and dacarbazine.

Although a wide variety of compounds, including nucleotides, may be delivered in accordance with the present invention, preferably the nucleotides are less than about 10,000 bases (or base pairs) in length, more preferably between about 20 to about 10,000 bases (or base pairs) in length, even more preferably between about 2,000 and about 8,000 bases (or base pairs) in length, and most preferably between about 4,000 and 6,000 bases (or base pairs) in length. Other (non-nucleotide) compounds or bioactive agents to be delivered are preferably less than about 5000 kilodaltons (5000 kD) in molecular weight, more preferably between about 10 and about 1000 kD, even more preferably between about 100 and about 500 kD. As one skilled in the art will recognize, however, larger and smaller sized compounds may also be delivered in accordance with the present invention.

The useful dosage of nucleotide sequences or other compounds to be administered or delivered, as well as the mode of administration, will vary depending upon type and nature of the compound to be delivered, the age, weight, cells or patient (animal) to be treated, the particular diagnostic, therapeutic, or other application intended (including the disease state, if any, to be treated), and the organic halide (if any) and carrier (if any) employed. Typically, dosage is initiated at lower levels and may be increased until the desired therapeutic effect is achieved. The desired dosage, including any therapeutically or diagnostically effective dosage amounts, will be well within the ambit of one skilled in the art, armed with the prevailing medical literature and with the present disclosure. Representative amounts are provided in the examples herein. Of course, higher or lower amounts may be employed, as will be recognized by the skilled artisan.

As one skilled in the art would recognize, administration of compositions of the present invention may be carried out in various fashions, such as intravascularly, intralymphatically, parenterally, subcutaneously, intramuscularly, intranasally, intrarectally, intraperitoneally, interstitially, into the airways via nebulizer, hyperbarically, orally, topically, or intratumorally, using a variety of dosage forms. One method of topical administration is the addition of a nucleotide sequence (or other compound to be delivered), preferably in a carrier such as and not limited to a

hydrogel, applied to the outside of a balloon catheter. The catheter is inserted into the blood stream of a patient. Once the balloon of the catheter reaches the location to which the sequence is to be administered, the balloon is pumped up and the sequence-containing hydrogel adheres to the blood vessel surface thus delivering the sequence.

- 5 In addition, ultrasound may be applied to the cells endoscopically and intravascularly, for example, as well as, of course, applied externally.

A number of transfection and other intracellular delivery techniques are possible in accordance with the methods of the present invention employing the subject methods and the organic halides and/or carriers as disclosed herein. Two methods,
10 using calcium phosphate and viral vectors, are indirect methods of introducing the nucleotide sequence into cells because they involve the passive uptake of the nucleotide sequence by the cell which is to be transfected.

Calcium phosphate coprecipitation is a chemical-mediated indirect method of transfection. The nucleotide sequence (or other compound to be
15 administered) is introduced into mammalian cells, for example, by coprecipitation of the sequence with calcium phosphate, calcium chloride, calcium hydroxybutarate, and the like; then the mixture is presented to the cells. The purified nucleotide sequence is mixed with buffers containing phosphate and calcium chloride which results in the formation of a very fine precipitate, and the mixture is presented to the cells in culture.
20 A protocol for cells that grow attached to a substratum as set forth in Keown, W. A., *et al.*, "Methods for Introducing DNA into Mammalian Cells," in *Methods in Enzymology, Vol. 185, Gene Expression Technology*, Ed., Goeddel, David V., pp. 527-537, Academic Press, Inc., New York, New York, 1991 is incorporated herein by reference in its entirety. Briefly, on day 1, cells are seeded at $2-3 \times 10^4$ cells/cm² in
25 normal growth medium and allowed to attach. At the time of transfecting, the cells should be 80-90% confluent. On day 2, the nucleotide sequence-calcium phosphate coprecipitate is prepared, mixed and allowed to stand at room temperature for about 30 minutes. The nucleotide sequence is added to TE buffer (10 mM tris, 1 mM EDTA Ph 8.0), 2X HBAS (Hanks' balanced salts, 1.4 mM Na₂HPO₄, 10 mM KCl, 12 mM
30 glucose, 275 mM NaCl, and 40 mM HEPES, pH 6.95), and 2M CaCl₂ (calcium chloride in 10 mM HEPES, pH 5.8). The medium is removed from the cells and replaced with fresh medium. The precipitate is mixed gently by shaking or pipetting

and added directly to the medium in dishes containing cells. The cells are incubated at 37° C for 4 hours. The medium containing the precipitate is removed and dimethyl sulfoxide in 1 X HBS. After 2 minutes, 4 ml of serum-free medium is added to each dish. The mixture is aspirated, washed twice with serum-free medium, and medium is added and incubated overnight at 37° C. The cells are trypsinized and the contents of each plate is split into 3-4 new plates. Selection may be applied for stable transfectants, in which selective medium may be used at this time or a day later.

The present invention employing the methods of the invention and the organic halides and/or carriers may also be useful concurrently with microinjection and electroporation. Microinjection involves the direct microinjection of nucleotide sequences into the nucleus of a host cell. Microinjection does not expose the nucleotide sequence to the cytoplasm or organelles within it. This is beneficial since considerable damage may result to the DNA during transit from the cell exterior to the nucleus. Electroporation involves electric field-mediated nucleotide sequence transfection. When membranes are subjected to an electric field of sufficiently high voltage, regions of the membrane undergo a reversible breakdown, resulting in the formation of pores large enough to permit the passage of nucleotide sequences. Electroporated nucleotide sequences remain free in the cytosol and nucleoplasm. Very few copies of transfected nucleotide sequences may be introduced with electroporation. Cells susceptible to electroporation include, for example, lymphocytes, hematopoietic stem cells, and rat hepatoma cells.

"Ultrasound", "Sonoporation™", and similar terms, refer to pulses of sound energy, preferably repetitive pulses, sufficient to assist in inducing the delivery of a compound into a cell, and, if desired, the formation of a gas from a gaseous precursor. Preferably, the ultrasound is in the frequency range of from about 10 kilohertz to less than about 50 megahertz and at an energy level of from about 200 milliwatts/cm² to about 10 watts/cm². While not intending to be bound to any particular theory of operation, the ultrasound may assist in the delivery of the compounds to the cells by inducing openings in the cell membrane, or perhaps bursting endosomes inside a cell allowing compounds to escape. Indeed, cells may be induced to take up (e.g., be transfected with) compounds (e.g., nucleotide sequences) with ease compared to conventional methods. Typically the ultrasound is applied by external

application, via a standard clinical ultrasound device, but may also be applied in other fashions, such as endoscopically and intravascularly, as described above. The use of ultrasound in connection with the present invention may, in certain embodiments, be preferred. However, as noted herein, the use of ultrasound is not necessary or critical
5 to the operation of the methods of the invention. Thus, the subject methods may be carried out with the application of ultrasound, or without the application of ultrasound, as desired.

In accordance with the present invention, for *in vivo* applications, a lower frequency of sound is usually selected for cells of deep seated or thick tissues,
10 e.g. transcutaneous application of ultrasound to cells of the deep seated muscle or organs in the abdomen or retroperitoneum. For cells of small tissues a higher frequency of sound energy is applied, e.g. for the eye. For intravascular applications, which may employ intravascular catheters equipped with ultrasound transducers for endovascular gene therapy, higher frequencies may be employed such as over about 20
15 megahertz. For most applications however the frequency of the sound ranges from about 500 kilohertz to about 3 megahertz, preferably from about 500 kilohertz to about 1 megahertz, more preferably about 200 kilohertz, more preferably about 40 kilohertz to about 25 megahertz, even more preferably about 10 megahertz. Compared to lithotripsy, the frequency employed in the present invention is more than about 2 or 3
20 orders of magnitude higher and the energy levels of the present invention are lower.

The sound energy is applied in waves of sonic energy over a given duty cycle (sometimes referred to as pulse duration) and level of intensity. Generally continuous wave ultrasound which applies a constant train of ultrasound pulses is employed. The duty cycle is selected so that the level of energy output is in a desired
25 range. The duty cycle may be varied from between 1% and 100% meaning that the ultrasound energy will be pulsing from between 1% and 100% of the time. For example, a period of ultrasound treatment may take place over 25 minutes with three duty cycles of ultrasound, each five minutes in duration, interrupted by two periods of no ultrasound. Preferably the duty cycle is 100%, more preferably about 75%, more
30 preferably about 50%, even more preferably about 20%, even more preferably about 15%, and even more preferably about 10%.

Ultrasound for use in the present invention is typically provided at a frequency lower than the frequency used for imaging by ultrasound. The frequency of ultrasound which is selected will vary depending upon the location of cells which are being transfected, and or other factors that will be readily apparent to one skilled in the art based upon the present disclosure.

In addition to frequency, the energy level (sometimes referred to as power intensity or power level) also has a large effect on total energy which is applied to the cells or tissue for ultrasound enhanced transfection. Suitable energy levels will be readily apparent to one skilled in the art based upon the present disclosure.

Typically, the energy level settings are somewhat higher than employed in diagnostic ultrasound but may range from about 500 milliwatts/cm² to about 10 watts/cm², more preferably from about 200 milliwatts/cm² to about 10 milliwatts/cm², and more preferably of from about 50 milliwatts/cm² to about 2 watts/cm². The power level which is applied is selected so that both peak spatial temporal power and total energy deposition is generally below the cytotoxic threshold for the cells or tissue. Generally, frequencies and energy levels are applied at lower amounts, then increased until the desired cellular uptake of the administered compound is achieved.

As one skilled in the art would recognize, high energies of ultrasound may be used for hyperthermia to heat the tissue and also to directly ablate tissues with very high levels of energy. In the ultrasound enhanced transfection and gene expression of the present invention, energy levels are far below those which cause tissue ablation and below those which cause a significant hyperthermic effect. As one skilled in the art would recognize once armed with the present disclosure, energy deposition is a function of both power intensity and duty cycle. Higher spatial peak temporal average power tends to shift the bioeffect curve such that lower total energy may be applied to create a greater bioeffect. Higher energy levels and lower ultrasonic frequencies are required for penetration into deep seated tissues; conversely lower energy levels and higher ultrasonic frequencies are needed for treatment of superficial tissues or when the ultrasound transducer can be applied directly to the tissue surface.

Small volume cell culture samples need less power for ultrasound enhanced transfection than large volume bioreactor chambers which may be multiple liters in size and

- 50 -

therefore need higher energy levels to enhance gene expression. The geometry of a cell culture container will also affect the ultrasound energy requirements.

In accordance with the present invention, ultrasound energy may be used to increase the efficiency of cellular uptake of a compound (e.g. transfection) by
5 inducing a cell to take up a compound. In addition, gene expression of a nucleotide sequence is enhanced by the application of ultrasound.

The ultrasound energy may be applied to the tissue or cells either before, simultaneously with, or after administration of the compound to the cell, preferably simultaneously with or after. Typically the ultrasound energy is applied from no more
10 than about 48 hours prior to administration of the compound or genetic material to the cells and/or up to no more than about 48 hours after the genetic material has been administered to the cell, although longer or shorter times may be applied. More preferably, the ultrasound energy is applied at some time or at various time points from about 4 hours before administration of the compound or genetic material up to
15 about 24 hours after administration. Most preferably the ultrasound energy is applied within about 1 hour prior to transfection up to about 12 hours post transfection.

Either one or multiple applications of ultrasound energy may be employed. The duration of ultrasound energy exposure (exposure time) will vary depending upon the power level of the ultrasound and the duty cycle. To determine
20 the preferable duration, ultrasound is typically applied at lower exposure times, and increased until the desired cellular uptake of the compound administered is achieved. A high intensity (high power level; typically greater than about 2 watts/cm², preferably over about 5 watts/cm², and also preferably over about 10 watts/cm², depending on the pulse duration) ultrasound shock wave may require only a few milliseconds of
25 exposure. This may also be the case when cavitation nuclei such as gas filled liposomes or perfluorocarbon emulsions are present within the medium. A very brief exposure to high energy ultrasound may be sufficient to enhance transfection. The presence of cavitation nuclei in the transfection medium will lower the cavitation threshold and therefore potentially decrease energy requirements for ultrasound
30 enhanced transfection as well as to potentially decrease the necessary exposure time. More typically the exposure time ranges from about a few seconds to up to about an hour of ultrasound energy application to the cell to achieve most effective ultrasound

enhanced gene transfection. Even more preferably the duration of ultrasound exposure ranges from about a few seconds to about a few minutes and may be repeated at various intervals during transfection. The duration of ultrasound energy exposure should be sufficient to cause the desired effect but not so long that significant
5 cytotoxicity may result.

The effect of ultrasound enhanced transfection is independent of hyperthermia. While the application of ultrasound energy necessary to increase the efficiency of transfection may result in a few degrees centigrade increase in temperature, any increase in temperature is typically transient and the temperature
10 rapidly returns to baseline. More preferably the temperature does not increase significantly during application of the ultrasound. An increase in temperature is typically less than about 1° C to about 2° C. Progressively higher levels of ultrasound energy will result in progressive rises in temperature but temperature is preferably maintained below the level where significant cytotoxicity will occur (e.g. 44° C or
15 higher). As one may note, the sample measures the temperature in a solution of normal saline when exposed to ultrasound. The applied energy is 10 watts imparted through a 5.0 cm² transducer, or 2 W cm⁻². Sound energy from the ultrasound transducer may be simply converted to thermal energy in the aqueous milieu. The amount of energy and/or the time of exposure may be modified so as to prevent
20 temperature-induced cell destruction.

The ultrasound energy may be applied with any of a variety of commercially available ultrasound systems. For example a Rich-Mar model 25 ultrasonic therapy apparatus (Rich-Mar Corporation, Inola, Oklahoma) with the center frequency residing at approximately 1.0 Mhz, in pulsed or continuous mode, may be
25 used to practice the invention. Conventionally available transducers, power amplifiers and other component systems for practicing the invention can also be readily assembled. Wave synthesizers and pulsers may also be incorporated into the system to allow control over the pulse repetition intervals, duty cycles, etc. Advantageously, these components can also be used to modify the ultrasound pulses to employ varying
30 frequency and amplitude effects such as CHIRP (increasing in frequency) and PRICH pulses (decreasing in frequency) waveform patterns. Ultrasonic energies can also be supplied from commercially available amplifiers, transducers and frequency generators.

By way of example, a power transducer with a center frequency of 1.0 Mhz from Valpey-Fisher (Valpey-Fisher, Hopkinton, Mass.), a power RF amplifier from ENI (ENI, Rochester, New York), and a function generator from Hewlett Packard (Hewlett Packard, Sunnyvale, Calif.) may be a suitable setup to accomplish the above goals.

5 Alternatively, a pulse/function generator or an arbitrary function generator may also be used to accomplish variable pulse formats. In addition, methods that would allow for gating the various signals together, could conceivably be accomplished.

The high energy ultrasound system may also be incorporated with ultrasound imaging such as described in U.S. patent application U.S. Serial No.
10 08/468,052, filed June 6, 1995, and the disclosures of which are hereby incorporated herein by reference in their entirety. Also application of high energy ultrasound may be performed under other forms of conventional imaging such as endoscopy (e.g. fiberoptic), computed tomography, magnetic resonance imaging, angiography, and nuclear medicine. Such imaging may be employed, for example, to locate and identify
15 in a patient the cells to which the ultrasound induced (or other) heating should be applied, or used to follow and/or locate the composition of the invention after administration to a patient.

The ultrasound may be applied so as to effectively create second harmonic superimposition on the target treatment zone of tissue to increase the
20 effectiveness of transfection. For example, a prototype sector-vortex phased array transducer, depicted in Figure 5, 120 mm in diameter, which generates 750 kHz and 1.5 MHz ultrasound may be employed. As described in the reference by K. Kawabata and S. Umemura, *Ultrasonics Sonochemistry* 1996, 3:1-5, a transducer may be constructed with 32 piezoelectric (PZT) transducer elements from lead zirconate PZT
25 material. The transducer may be constructed in two tracks such that there are 16 sectors in each track. The lower frequency ultrasound could be applied from the outer track and the higher frequency, 1.5 MHz, from the inner track. A shell may be constructed with a 120 mm radius of curvature for geometric focusing. The beam profile provided by the piezoelectric elements and spherical shape of the transducer cell
30 assembly can be designed so as to superimpose the focal zones of the two different frequencies of ultrasound. This may result in focal acoustic power with superimposition of the lower frequency and higher frequency ultrasound sources. This

results effectively in second harmonic superimposition of the ultrasound signal. While not intending to be bound by any particular theory of operation, it is believed that this ultrasound assembly will allow for improved transfection efficiency at lower total amounts of energy and thus result in reducing damage to the cell.

5 Skilled artisans would recognize, once armed with the present disclosure, that the two ultrasound energy sources may be at other frequencies such that the first source (low frequency) is one half the frequency of the second source. For example, 500 kHz in the outer assembly and 1 MHz in the inner assembly may be employed. A range of different frequencies may be selected such that the outer
10 assembly is 1X and the inner assembly is 2X. Alternatively, the assemblies may be designed such that the higher frequency is in the outer assembly and the lower frequency is in the inner assembly. Alternatively still, odd harmonics may be utilized such that the outer and inner tracks may be represented by X and 3X frequencies or X and 5X frequencies. The second harmonic, ultraharmonic, or subharmonic frequencies
15 are superimposed at the focal zone which is directed towards the target tissues or cells to be transfected. Thus, ultrasound may be administered simultaneously at two or more frequencies to result in superimposition of ultrasonic frequencies, including and not limited to second harmonic frequencies.

The present invention is also directed to a pharmaceutical kit which
20 comprises a compound to be delivered, an organic halide and/or a carrier (including combinations thereof) for use to those desirous of delivering to a cell a compound. The compound, organic halide, and/or carrier may be mixed together or separately provided (as in, for example, separate containers, such as separate vials or packets). The pharmaceutical kit may further comprise conventional kit components known to
25 those skilled in the art once armed with the present disclosure, such as, mixing vials, syringes, gauze, etc.

The invention is further demonstrated in the following actual Examples 1-3, 10-19, and 23, and prophetic Examples 4-9, and 20-22. The examples, however, are not intended to in any way limit the scope of the present invention.

EXAMPLES**Example 1: Effect of Ultrasound on the Temperature of an Aqueous-Based Medium in Culture Plate Well Phantoms and on Cell Viability**

The first phase of evaluating the effect of ultrasound was to measure the amount of heating caused by the ultrasound energy. The experimental protocol was designed to evaluate the heating in an individual well of a 6 well culture plate while exposed to ultrasound. Ultrasound was applied for 30 seconds to each well and the relationship between energy and heating is shown in Table 2 below.

Table 2

<i>Energy</i>	<i>Temperature increase at 10% Duty Cycle</i>	<i>Temperature increase at 100% Duty Cycle</i>
0.5 W/cm ²	0°C	0.5°C
1 W/cm ²	0°C	1.5°C
2 W/cm ²	0.5°C	2.9°C

A follow-up experiment was carried out to assay the cell viability after ultrasound exposure. A cell proliferation kit using sodium 3'-[1-(phenylamino-carbonyl)3,4-tetrazolium]-bis (4-methoxy-6-nitro)benzene sulfonic acid hydrate (XTT, Boehringer-Mannheim, Indianapolis, Ind.) as the cell viability indicator was carried out to evaluate whether cell damage had occurred. In this experiment, higher absorbance is due to viable cells causing uptake of XTT. Table 3 contains the results from this study.

Table 3**Cell Viability as a Function of Ultrasound Power Input**

<i>Treatment</i>	<i>Mean absorbance</i>	<i>Standard Deviation</i>
No Ultrasound	7.83	0.41
0.5 W/cm ² 10% Duty Cycle	7.83	0.41
0.5 W/cm ² 100% Duty Cycle	7.83	0.41
1 W/cm ² 10% Duty Cycle	7.17	0.75
1 W/cm ² 100% Duty Cycle	6.00	1.41

1.5 W/cm ² 10% Duty Cycle	7.67	0.82
1.5 W/cm ² 100% Duty Cycle	1.83	0.98
2 W/cm ² 10% Duty Cycle	6.83	0.75
2 W/cm ² 100% Duty Cycle	1.60	0.55

5 As the data in Table 3 shows, the first noticeable change in cell viability occurs with an energy of 1 W/cm² and a 100% Duty Cycle. At higher energies with a 100% duty cycle a significantly larger number of cells are destroyed.

Example 2: Effect of Ultrasound on Gene Expression in Cell Culture

Materials and Methods for Transfection and Measurement of Gene Expression

10 The DNA plasmid used was pCAT Control (GenBank accession number X65321) (Promega, Madison, WI) (see Figure 3).

 The plasmid was transformed into DH5- α *Escherichia coli* competent cells (Life Technologies, Gaithersburg, MD). The cells were plated on LB agar plates (Bio 101, Vista, CA) that contained ampicillin (Boehringer Mannheim Biochemicals
15 (BMB), Indianapolis, IN). Resistant colonies were selected, grown up and a Wizard mini-prep (Promega) plasmid DNA extraction was carried out. Plasmid DNA was cut with restriction enzyme EcoRI (BMB) and run on a 1% agarose gel (BMB). After fragments were evaluated for size, the remaining culture was used to start a large culture and a Wizard maxi-prep was carried out to produce DNA for transfection. The
20 DNA was quantified using a Hoefer TKO-100 mini-DNA fluorometer. The DNA was then ready for use in transfections.

 Cationic liposomes were made by mixing dipalmitoyl ethylphosphocholine and dioleoyl phosphoethanolamine (Avanti Polar Lipids Alabaster, AL). The lipid mixture was resuspended in water and then sonicated to
25 form small liposomes.

 A human cervical cancer cell line (HeLa) was obtained from the American Type Culture Collection (Rockville, MD) and grown in EMEM culture media (Mediatech, Washington, D.C.) supplemented with calf serum (Life Technologies). These cells were used in the transfections.

30 The DNA/lipid complex was formed in HEPES buffered saline (HEPES 20 mmol/l, NaCl, 150 mmol/l, pH 7.4) (Sigma, St. Louis, MO) by mixing the lipid

and DNA at a ratio of 6 parts lipid to one part DNA. This was incubated for 30 minutes at room temperature and then used for transfection.

The pCAT control plasmid encodes for the enzyme chloramphenicol acetyl transferase (CAT). This enzyme is not found in mammalian systems. The CAT
5 expression is assayed using a CAT ELISA kit (BMB). This non-radioactive kit allows for sensitive detection of CAT expression. The kit is based on a sandwich of antibodies. A 96 well plate is coated with anti-CAT, this antibody binds the CAT in the sample. The next antibody is the anti-CAT-digoxigenin, digoxigenin is a hapten found only in the digitalis plant. The rarity of this compound makes it ideal for non-
10 radioactive labelling. The next antibody added is an anti-digoxigenin that has been labelled with horseradish peroxidase. Horseradish peroxidase breaks down a substrate and causes a color reaction which is then read with an SLT Spectra Shell plate reader (SLT-Labinstruments Ges.m.b.h., Groedin/Salzburg, Austria). Using a standard curve, this plate reader allows for measurement of protein concentration.

15 Protocol

The DNA complex was formed and added at a concentration of 30 μg of lipid and 5 μg of DNA per well in a 6 well plate containing HeLa cells in 4 mls of EMEM. A Rich-Mar model 25 therapeutic ultrasound machine (Rich-Mar Corporation, Inola, OK) was used to apply ultrasound to the wells of the 6 well plate.
20 The ultrasound was applied either 30 minutes before the DNA/lipid complex was added, 1 hour after the complex was added or 4 hours after the complex was added. In the first experiment, a standoff pad was used that covered the entire base of the 6 well plate and allowed sound to conduct from one well to another. The power setting was 0.5 w/cm^2 with a 10 % duty cycle.

25 Three conditions were tested. No ultrasound, ultrasound applied 30 minutes before the transfection and ultrasound applied 1 hour after the transfection.

The results set forth in Table 4 are from a transfection with a 1:1 mix of dipalmitoylethyphosphocholine and dioleoyl phosphoethanolamine (Avanti Polar Lipids, Alabaster, AL). The transfection was carried out in the presence of serum. In
30 addition, a negative control was added which included cells grown up not transfected with the 1:1 mix of dipalmitoylethyphosphocholine and dioleoyl phosphoethanolamine and without ultrasound treatment.

Table 4
Quantification of Gene Expression in Cells Exposed to Ultrasound

<i>Treatment</i>	<i>Cat expression (ng/ml)</i>
negative control	0
5 no ultrasound	15.876
Ultrasound 30' pretreatment	20.529
Ultrasound 1 hour post treatment	43.794

10 This experiment was repeated with a standoff pad designed to isolate the wells from each other, see Figure 1 and Figure 4. The base of a 6 well plate was cut away to allow transducer access and a second 6 well plate was inverted above it. 2% agarose was poured onto this mold to form a standoff pad. The standoff pad was constructed to allow for open (dead air) spaces between the portions of the standoff pad

15 that contacted the 6 well plate, such that each well was raised above the standoff pad on a vertical support with open spaces under each of the wells where the standoff pad was cut away. The vertical supports were made of 2% agarose and conducted the sound from the ultrasound transducer. The transducer was placed below the standoff pad and sound was projected up through the pad into the each of the wells of the 6

20 well plate. The 6 well plate was placed upright on the standoff pad such that the cells on the bottom of the well were close to the transducer. In both experiments, the expression of the CAT protein was measured by CAT ELISA after 48 hours of incubation. Ultrasound was applied at 1 W/cm² and 100% duty cycle. The ultrasound was applied for 30 seconds on each well.

25 The same transfection reagent was used as in the first example. The test conditions were no ultrasound, 30 minutes before transfection, 1 hour after transfection and 4 hours post transfection. Again the transfection was carried out in the presence of serum. In addition, a negative control was added which included cells grown up not transfected with CAT/lipid complex and without ultrasound treatment. The results are

30 shown in Table 5.

Table 5

<i>Treatment</i>	<i>Cat expression (ng/ml)</i>
negative control	0
no ultrasound	5.339
5 Ultrasound 30' pretreatment	5.339
Ultrasound 1 hour post treatment	10.078
10 Ultrasound 4 hours post treatment	4.988

Example 3: Application Using DNA with a Lipid Carrier and a Cavitator

The cells and the DNA/lipid complex were prepared as in Example 2. Six well plates were seeded with HeLa cells and filled with 16 ml of media as in Example 2. The lipid added was increased to 135 μg to allow for the increase in volume and the DNA was also increased to 22.5 μg per well. One hour after the complex was added, 100 μl of a liposome comprised of the lipids dipalmitoylphosphatidylcholine (DPPC), dipalmitoylphosphatidylethanolamine coupled to polyethylene glycol 5000 (DPPE-PEG5000), and dipalmitoylphosphatidic acid (DPPA), in a ratio of about 82%:8%:10% (mole %) was added to each well. The DPPE-PEG5000 was comprised of DPPE and PEG5000 in a ratio of about 20%:80% (weight %). PEG5000 refers to PEG having an average molecular weight of about 5000. In addition, a negative control was added which included cells grown up not transfected with CAT/lipid complex and without ultrasound treatment.

The six well plate was then covered with a sheet of parafilm to prevent leakage, the lid was replaced and the plate was inverted. By inverting the plate, the gas filled liposomes (cavitator) were allowed to float up to the cells, now on top of the standoff pad, plate construct. The ultrasound was applied from the bottom, however, in this case, the sound was propagated through the media to the cells. After the ultrasound exposure the plates were returned to an upright position and the parafilm

removed. The plates were then incubated for 4 hours and the CAT ELISA performed the results of which are set forth in Table 6.

Table 6

5	<u>Treatment</u>	<u>Cat expression in ng/ml</u>
	Negative control	0
	No ultrasound	4.584
	0.5 w/cm ² /35% duty cycle	9.634
	0.5 w/cm ² /100% duty cycle	19.910
10	1 W/cm ² /100% duty cycle	9.811

Example 4: Industrial Applications of Ultrasound Enhanced Transfection

A large scale bioreactor vessel containing a free suspension of cells is equipped with a flow through chamber housing an ultrasound transducer. Plasmid DNA containing the gene of interest is added to the cell suspension with and without
 15 an organic halide. As the cells circulate through the chamber 500 kilohertz ultrasound is applied with a 10 percent duty cycle at an energy level of 200 milliwatts per cm². Enhanced gene expression is attained, both with and without the organic halide. By varying the rate of flow of the cell suspension through the flow through chamber the proper ultrasound exposure time is attained for optimal transfection efficiency.

20 **Example 5: *Ex Vivo* Enhancement of Gene Expression in Human Cells**

Plasmaphoresis is used to harvest the T cells of a patient with metastatic malignant melanoma. The T cells are placed in tissue culture and incubated with granulocyte macrophage colony stimulating factor (GMCSF) to increase multiplication of the lymphocytes. After sufficient cell densities have been achieved the gene for
 25 interleukin-2 (IL-2) is added to the cells with a cationic liposomal vector, with and without an organic halide. One hour later 1 megahertz ultrasound energy is applied at a power level of 0.5 watts with a 10 % duty cycle for a duration of 5 minutes. Twenty-four hours later the cells are infused back into the patient in an effort to treat the metastatic tumors. Promising results in the form of a perceptible decrease in tumor

mass are observed, both with and without the organic halide. Additional testing also reveals enhanced IL-2 expression in the treated cells.

Example 6: Therapeutic Applications of Ultrasound Mediated Gene Delivery: Duchenne's Muscular Dystrophy

5 In a patient with Duchenne's Muscular Dystrophy plasmid DNA encoding the gene for dystrophin is injected at multiple sites into the muscles of the thighs and legs, with and without an organic halide. Ultrasound is then applied to the thighs and legs using silicone gel as couplant between the transducer and the patient's skin. The frequency is 200 kilohertz with a 10 % duty cycle and a power level of 1
10 watt. The transducer remains for about 2 to 3 minutes over any one location on the skin. Enhanced expression for the gene for dystrophin is attained resulting in increased muscle strength, both with and without the organic halide.

Example 7: Therapeutic Applications of Ultrasound Mediated Gene Delivery: Atherosclerotic Heart Disease

15 A patient with atherosclerotic disease has marked narrowing of the left anterior coronary artery. A balloon angioplasty catheter coated with a hydrogel material binding the gene for vascular endothelial growth factor (VEGF), both with and without an organic halide, is placed at the site of arterial stenosis and the balloon is inflated to a pressure of 9 atmospheres. An endovascular ultrasound catheter is placed
20 inside the vessel at the region where the angioplasty was performed and ultrasound energy is applied. The frequency is 20 megahertz at 1 watt per cm² with 15 % duty cycle for 3 minutes. Enhanced gene expression of VEGF is observed with diminished propensity to restenosis at the angioplasty site, both with and without the organic halide.

25 **Example 8: Therapeutic Applications of ultrasound mediated Gene Delivery**

 Similarly to Example 7 angioplasty is performed in a patient using a balloon catheter coated with the gene for VEGF, and with and without an organic halide, but in this case the ultrasound energy is applied transcutaneously with a 1 megahertz focused transducer equipped with both imaging and therapeutic elements.
30 The therapeutic 1 megahertz sound is applied at an energy level of 500 milliwatts/cm²

using a 20 % duty cycle for a period of 5 minutes. The energy is focused upon the angioplasty site. Again enhanced VEGF gene expression is observed and decreased propensity to restenosis, both with and without the organic halide.

Example 9: Therapeutic Applications of Ultrasound Mediated Gene Delivery

5 Colonoscopy is performed in a patient with genetic predisposition to colon cancer. A region of epithelial metaplasia is identified in the descending colon. An ultrasound transducer equipped with a semipermeable membrane and drug storage reservoir containing the gene for Bcl 2 with a liposomal vector, both with and without an organic halide, is positioned over the area of epithelial metaplasia and ultrasound
10 energy is applied at a frequency of 500 kilohertz with an energy level of 500 milliwatts/cm² and 10% duty cycle for a period of 3 to 5 minutes, to deliver the Bcl 2 gene to the cells in the region. On follow-up colonoscopy 8 weeks later the epithelial metaplasia has decreased significantly, particularly where an organic halide is employed in the administration process. Further testing reveals enhanced Bcl 2
15 expression in the region, both with and without the organic halide employed in the delivery process.

Example 10: Transfection Efficiency of DPEPC/DOPE With and Without Organic Halides

Dipalmitoylethylphosphocholine (DPEPC) (Avanti Polar Lipids,
20 Alabaster, AL) was mixed with dioleoylphosphatidylethanolamine (DOPE) (Avanti Polar Lipids, Alabaster, AL) at a 1:1 (w:w) ratio in 10 ml of deionized water at a lipid concentration of 1 mg per ml. 100 microliters of n-perfluorohexane (PCR, Inc., Gainesville, FL) was added and mixed by shaking for 5 minutes on a Heavy Duty #6 Wig-L-Bug (Crescent Dental, Lyons, IL). The mixture was then extruded five times
25 through two 0.8 μ m filters in a Lipex Biomembranes Extruder Device (Vancouver, BC, Canada). Particles without a fluorinated organic halide were sonicated for 10 minutes at room temperature in a bath sonicator. The mixture was then diluted in HEPES buffered saline at a ratio of 30 μ l of lipid mix to 70 μ l of HBS per well.
pCMVCAT (Life Technologies, Inc., Gaithersburg, MD) containing the gene for
30 chloramphenicol acetyl transferase and the promoter from human cytomegalovirus

(CMV) was used to transfect HeLa cells. pCMVCAT may be produced in accordance with the methods set forth in Foecking and Hofstetter, *Gene* **1986** 45:101-105, incorporated herein by reference in its entirety.

The pCAT[®] (Promega, Montgomeryville, PA) basic vector lacks
 5 eukaryotic promoter and enhancer sequences. This allows maximum flexibility in cloning any putative regulatory sequences into the convenient multiple cloning sites. Expression of CAT activity in cells transfected with this vector is dependent on insertion of a functional promoter upstream from the CAT gene. Enhancer elements can be inserted at the *BamH* I site downstream from the CAT gene. The vector map
 10 sequence reference points are multiple cloning sites (*Hind* III-*Xba* I) 2242-2271, SV40 small T antigen region 3064-3917, CAT gene start site 2315, CAT gene stop site 2974, and β -lactamase (*Amp*'^r) coding region 209-1069.

Plasmid DNA was diluted to 5 μ g per 100 μ l in HBS. The DNA and lipid
 15 mixes were combined and incubated for 45 minutes at room temperature. HeLa cells (ATCC certified cell line 2 (CCL 2)) were plated at a concentration of 4 x 10⁵ per well in Eagle's MEM with non-essential amino acids and Earle's BSS, 90%; fetal bovine serum, 10%. 200 μ l of the lipid/DNA complex were added to each well and incubated 48-72 hours in the presence of serum. The process was repeated using n-
 20 perfluorohexane in volumes of 50, 25, and 12.5 microliters. CAT expression was assayed using a CAT ELISA from Boehringer Mannheim Biochemical (Indianapolis, IN). The results are shown in Table 7.

Table 7. Effect of Various Amount of Organic Halide on Chloramphenical Transacetylase Expression in Various Cell Lines

Lipids	Organic Halide (OH)	OH Volume μ l	Cell Line	CAT Expression	Standard Deviation
25 Lipofectin	None		HeLa	59.624	6.828
Lipofectamine	None		HeLa	27.917	5.112
Lipofectin	None		C127	0	1.582
Lipofectamine	None		C127	0	3.164
Lipofectin	None		COS1	104.424	117.883

	Lipofectamine	None		COS1	305.392	23.254
	Lipofectin	None		NIH3t3	0	1.582
	Lipofectamine	None		NIH3t3	5.766	8.809
	DPEPC/DOPE	None		HeLa	28.946	11.852
5	DPEPC/DOPE	None		C127	24.493	21.491
	DPEPC/DOPE	None		COS1	4930.403	262.278
	DPEPC/DOPE	None		NIH3t3	36.368	21.952
	DPEPC/DOPE	Perfluorohexane	12.5	HeLa	3642.958	229.17
	DPEPC/DOPE	Perfluorohexane	25	HeLa	126.976	19.126
10	DPEPC/DOPE	Perfluorohexane	50	HeLa	33.454	10.94
	DPEPC/DOPE	Perfluorohexane	100	HeLa	28.69	2.61
	DPEPC/DOPE	Bromononafluorobutane	12.5	HeLa	1795.29	1054.14
	DPEPC/DOPE	Bromononafluorobutane	25	HeLa	2725.611	1004.542
	DPEPC/DOPE	Bromononafluorobutane	50	HeLa	2634.161	456.709
15	DPEPC/DOPE	Bromononafluorobutane	100	HeLa	2703.144	600.767
	DPEPC/DOPE	Perfluorohexane	12.5	C127	167.911	88.724
	DPEPC/DOPE	Perfluorohexane	12.5	COS1	5348.326	93.809
	DPEPC/DOPE	Perfluorohexane	12.5	NIH3t3	1968.405	316.894

* DPEPC/DOPE is dipalmitoylethylphosphatidylcholine:

20 dioleylethylphosphatidylethanolamine; CAT expression units are ng/ml (protein).

Example 11: Transfection Efficiency of DPEPC With Organic Halides

An example of transfection of DPEPC with perfluorohexane and 1-bromononafluorobutane (BNFB, Fluoroseal, Houston, TX) was carried out. Particles
 25 were prepared as set forth in Example 10 except that the BNFB sample was cooled before and after shaking on the Wig-L-Bug to keep the BNFB in the liquid state. The results are shown in Table 7.

Example 12: Improved Transfection in Cell Lines Normally Resistant to Transfection With Perfluorohexane

COS-1 cells (ATCC cell repository line 1650(CRL 1650)) were propagated in Dulbecco's modified Eagle's medium, 90% and fetal bovine serum, 10% and plated at a concentration of 1×10^5 per well. NIH/3T3 cells (ATCC cell repository line 1658 (CRL 1658)) were propagated in Dulbecco's modified Eagle's medium with 4.5 g/liter glucose, 90% and calf serum, 10% and plated at a concentration of 1×10^5 per well. C127:LT cells(ATCC cell repository line 1804 (CRL 1804)) were propagated in Dulbecco's modified Eagle's medium with 4.5 g/liter glucose, 90% and fetal bovine serum, 10% and plated at a concentration of 1×10^5 per well. DPEPC:DOPE was prepared with perfluorohexane at a volume of 12.5 microliters and without perfluorohexane as Example 10. The lipid/DNA mixtures were incubated with the cells for 72 hours as described in Example 10. Lipofectin and Lipofectamine (Life Technologies, Gaithersburg, MD), commercially available controls, were used according to the manufacturer's instructions. The results are shown in Table 7.

Example 13: Transfection Using Cationic Microspheres Filled with Perfluorobutane Gas

A lipid solution with 1 mg per ml of lipid composed of 1:1 (w:w) DPEPC with dipalmitoylphosphatidylethanolamine (DPPE) was prepared and placed in a 2 ml vial with a head space of perfluorobutane gas. The samples were shaken for 1 minute of an ESPE CapMix at 4500 RPM resulting in gas filled lipid coated microspheres. To each sample pCMVCAT was added at a DNA concentration of $1 \mu\text{g}$ per $6 \mu\text{g}$ lipid. The process was repeated using 1:1 w:w DPEPC with DOPE. The gas filled microspheres prepared from DPEPC/DPPE (gel state saturated lipids) formed stable gas filled microspheres binding the DNA. When transfection experiments were repeated substantially as outlined in Example 11, however, there was no evidence of any appreciable gene expression. When gas filled microspheres were prepared from the DPEPC/DOPE lipids (DOPE is liquid crystalline state at physiologically relevant temperature) the particle count was lower than for the DPEPC/DPPE vesicles. When DNA was added to the lipids, the vesicles fell apart, indicating how cationic lipid microspheres composed of liquid crystalline state lipid are unstable to bind DNA when

the interior of the microsphere is filled with a gas PFC (perfluorobutane) as opposed to a liquid PFC (see above).

Example 14: Transfection With Organic Halides

The experiment conducted in Example 12 was repeated except that
 5 fluorinated organic halides were used in eight samples and eight samples were
 subjected to ultrasound. Sixty minutes following the incubation of the DNA/lipid
 complex with the cells, ultrasound was applied by immersing the head of a 1Mz
 transducer directly to the top of the cell culture well and ultrasound was applied for 5
 to 30 seconds at a 10% duty cycle. Control groups were cells not exposed to
 10 ultrasound with and without transfection materials. Table 8 indicates that organic
 halides increase the efficiency of ultrasound such that lower levels of energy are more
 effective. 1-bromononafluorobutane (BNFB) together with ultrasound results in about
 a 50% enhancement of expression; whereas about a 30% enhancement of expression is
 evident with perfluorohexane (PFC6) and ultrasound.

15 Table 8

	<u>Lipids</u>	<u>OH</u>	<u>US</u> <u>(sec.)</u>	<u>Expression</u> <u>Actual</u>	<u>SD</u>
	DPEPC/DOPE	BNFB	0	7007	2084
	DPEPC/DOPE	BNFB	5	10442	610
20	DPEPC/DOPE	BNFB	15	9910	656
	DPEPC/DOPE	BNFB	30	9381	140
	none	---	0	-137	23
	DPEPC/DOPE	---	0	1647	396
25	DPEPC/DOPE	---	5	6444	846
	DPEPC/DOPE	---	30	8167	1206
	Lipofectamine	---	0	389	125
	Lipofectin	---	0	-118	14
30	DPEPC/DOPE	PFC6	0	7290	2235
	DPEPC/DOPE	PFC6	5	9477	1017
	DPEPC/DOPE	PFC6	15	8545	401
	DPEPC/DOPE	PFC6	30	9630	827

In all cases above the cell line is NIH/3T3. Units of DNA expression are ng/ml protein. Ultrasound was applied at 0.5 W/cm², 10% duty cycle. OH-organic halide, US (sec.) - ultrasound in seconds, BNFB - (1-bromonanofluorobutane), PFC6 - (perfluorohexane), SD - standard deviation.

5 As can be seen above the lipid mixture of DPEPC/DOPE carrying the gene results in above background expression compared to Lipofectin or Lipofectamine. This expression is enhanced with the addition of either a fluorocarbon or by ultrasound. The best results were obtained with fluorocarbons and ultrasound in combination.

10 Example 15: Transfection With Perfluoroethers

The experiment described in Example 10 was repeated with the following perfluoroethers: perfluoromethylbutyl ether (PFMBE), perfluoro-4-methyl-tetrahydrofuran (PMTH) and perfluorotetrahydropyran (PFTH). Transfection data is shown in Table 9 below. Table 9 shows that perfluoroethers perform similar to
 15 perfluorocarbons of the previous examples. Increased levels of perfluoroethers do not appear to have a detrimental effect on transfection and expression. Each of the perfluoroethers enhance transfection greater than 100% over the control lipid (DODO).

Table 9

	<u>Lipids</u>	<u>Perfluoroether</u>	<u>PFE (vol)</u>	<u>CAT expression</u>	<u>Std. Dev.</u>
20	(none)	none	-----	-54.773	4.957
	DODO	none	-----	1490.801	183.278
	DODO	PFMBE	0.125 mls	3578.363	55.702
	DODO	PFMBE	0.250 mls	3167.014	246.912
	DODO	PFMBE	0.500 mls	3509.693	109.497
25	DODO	PFMTH	0.250 mls	3424.945	25.837
	DODO	PFMTH	0.500 mls	3373.024	36.736
	DODO	PFTH	0.250 mls	3306.029	67.332
	DODO	PFTH	0.500 mls	3344.886	235.041

30 In all cases above the cell line is HeLa, and the lipid coating for the perfluoroether dioleoyl-glycero-3 phosphocholine. CAT expression units are ng/ml protein. Std. dev. - standard deviation, PFE (vol) - perfluoroether in volume.

Example 16: Transfection Efficiency With Perfluorohexane

The experiment of Example 10 was repeated in HeLa cells using DMRIE-C, DODO, DPDO, or other commercial cationic lipids with and without perfluorohexane. The results are shown in Table 10 below. Table 10 shows that 5 perfluorocarbons are effective with a variety of lipids. Indeed, the enhancement of expression is independent of the type of lipid used. DODO + PFC6 results in about 8 to about 10 fold increase in expression, DMRIE-C results in about a 40% enhancement of expression, and DPDO results in about a 4 fold increase.

Table 10

			<u>CAT</u>		
	<u>Lipids</u>	<u>PFC</u>	<u>PFC (vol)</u>	<u>expression</u>	
				<u>Std. Dev.</u>	
10	(none)	none	-----	-5.608	5.015
	DMRIE-C	none	-----	1615.096	79.088
	DMRIE-C	PFC6	0.125 mls	2118.489	72.325
15	DODO	none	-----	611.594	228.548
	DODO	PFC6	0.250 mls	6331.664	443.727
	DODO	PFC6	0.500 mls	4829.148	379.244
	DPDO	none	-----	426.652	238.019
	DPDO	PFC6	0.125 mls	1675.285	1146.279
20	Lipofectamine	none	-----	-8.891	1.895
	Lipofectin	none	-----	100.542	56.863

DODO - dioleoyl-glycero-3 phosphoethylcholine. CAT expression units are ng/ml protein. DPDO - dipalmitoyl-glycero-3 phosphocholine, Std. Dev. - 25 standard deviation, PFC (vol) - perfluorocarbon in volume.

Example 17: Effect of Ultrasound Alone on DMRIE and DODO Vesicle Transfection

The experiments described above in the previous examples were repeated using the DMRIE, DODO, and no lipids, in each case without an organic halide, using 30 the same procedures set forth above in Example 16.

Table 11

<u>Lipids</u>	<u>OH</u>	<u>US (sec.)</u>	<u>Expression Actual</u>	<u>SD</u>
none	none	0	76	4
5 DMRIE	none	0	426	49
DMRIE	none	5	1450	317
DMRIE	none	30	1204	120
DODO	none	0	2719	102
DODO	none	5	4073	61
10 DODO	none	30	3914	53

=====

In all cases above the cell line is HeLa. Units of DNA expression are ng/ml protein. Ultrasound was applied at 0.5 W/cm², 10% duty cycle. OH - organic halide, PFC - perfluorocarbon, US (sec.) - ultrasound in seconds, SD - standard deviation.

Example 18: Effect of Poly-L-Lysine (in place of lipids) on Transfection With Perfluorohexane

The experiments described above in the previous examples were repeated using the DODO with or without a fluorinated organic halide, Poly-L-Lys with or without a fluorinated organic halide, and no lipids and no organic halide, using the same procedures set forth above in Example 16.

Table 12

<u>Carrier</u>	<u>OH</u>	<u>OH (vol)</u>	<u>CAT expression</u>	<u>Std. Dev.</u>
25 (none)	none	-----	1.378	1.012
DODO	none	-----	2190.158	684.125
DODO	PFC6	0.125	3322.927	39.520
Poly-L-Lys	none	-----	37.901	2.072
Poly-L-Lys	PFC6	0.125	50.909	5.128

DODO - dioleoyl-glycero-3 phosphoethylcholine. CAT expression units are ng/ml protein. OH - organic halide, OH (vol) - organic halide in volume in mls, Std. Dev. - standard deviation.

Example 19: Comparison of Different Organic Halides as Transfection Enhancers

5 The experiment was carried out as in Example 10 using HeLa cells, dioleoyl-glycero-3-phosphoethanolamine (DOPE) as the lipid carrier and either perfluoropentane (PFC₅), 1-bromoperfluorooctane (perfluoro-octylbromide, BrPFC₈), perfluorodecane (PFC₁₀) or perfluorohexane (PFC₆). The Table 13 illustrates the transfection results.

10 Table 13

	<u>Lipids</u>	<u>OH</u>	<u>OH vol (in mls)</u>	<u>CAT expression</u>	<u>Std. Dev.</u>
	(none)	none	----	-11.434	1.478
	DOPE	none	----	295.447	18.828
15	DOPE	PFC5	0.125	1204.762	198.020
	DOPE	PFC5	0.250	900.344	247.634
	DOPE	PFC5	0.500	1089.989	245.888
	DOPE	BrPFC8	0.125	276.236	57.468
	DOPE	BrPFC8	0.250	248.652	26.723
20	DOPE	BrPFC8	0.500	114.175	65.473
	DOPE	PFC10	0.125	839.263	302.202
	DOPE	PFC10	0.250	811.678	171.344
	DOPE	PFC10	0.500	1186.044	322.248
	DOPE	PFC6	0.125	1108.215	164.989
25	DOPE	PFC6	0.250	829.904	156.464
	DOPE	PFC6	0.500	441.745	33.219

OH - organic halide, OH (vol) - organic halide in volume, Std. Dev. - standard deviation.

The above results indicate that liquid (perfluorohexane or perfluorodecane) perfluorocarbons work as well as perfluorocarbons which would undergo at least a partial liquid to gas phase transition at physiological temperatures (perfluoropentane). Only the brominated compound, BrPFC₈, was markedly less effective in enhancing transduction.

The data also indicate that a preferred quantity of perfluorocarbon for transfection generally is in the range of 0.125 mls to 0.250 mls or from about 1% to 3% v/v.

Example 20: Transfection in the Presence of Fluorinated Surfactants

The experiment described in Example 10 is repeated except the lipids are suspended in varying amounts (1.25% to 5%) of Zonyl[®] surfactant, (Du Pont Chemical Co., Wilmington, DE). In some samples perfluorohexane (0.125 mls, 0.250 mls or 0.500 mls) is shaken with the surfactant. The sizes range from about 300 nm to about 900 nm. Transfection efficiency where samples are prepared from Zonyl[®] is about 10% to about 25% of the transfection where samples are prepared without Zonyl[®].

Example 21: Transfection with Cationic Lipid Carrier and Lipid Suspension With Organic Halides and With and Without Ultrasound

The experiment described in Example 14 is modified such that the control lipid mixture is DPPC/DPPA/PEG-5000 + perfluoropropane and results are compared to transfection using a suspension of the cationic lipid DOTMA + perfluoropropane. After incubation ultrasound is applied as in Example 14 to some of the samples. Results similar to those obtained in Example 14 are observed.

Example 22: Transfection with Cationic Lipid Carrier and Lipid Suspension With Ultrasound and 1-Bromononafluorobutane

Cationic liposomes are prepared from dioleoylphosphocholine and DOPE at a concentration of 1 mg/ml lipid. To this is added 0.125 μ l 1-bromononafluorobutane (BNFB). The mixture is agitated with a Wig-L-Bug for 60 seconds and the resulting vesicles are extruded with a 0.8 micron filter. The resulting BNFB filled cationic liposomes are then complexed with ribozymal RNA (hammerhead motif) encoding catalytic RNA specific for vascular endothelial growth factor (VEGF) at a

lipid to RNA ratio of 1:6 using conventional methods. The liposomal RNA preparation (1.0 ml) is injected IV into a patient with diabetic retinopathy. A 5 megahertz ultrasound transducer is placed on the patient's anesthetized cornea using a silicone acoustic coupling gel. Ultrasound energy is focused onto the patient's retina using 2.0 Watts and a 10% duty cycle. As the liposomes enter the region of ultrasound the gaseous precursor expands and pulsates. Local shock waves are created. The ribozyme RNA is delivered to the endothelial cells in the region of ultrasound application the therapeutic RNA construct enters the target endothelial cells. Catalytic RNA then causes reduction in VEGF production. The patient's retinal deterioration is halted and blindness is avoided.

Example 23: In Vivo Transfection Using Perfluorocarbons

Liposomes were prepared from dipalmitoylethylphosphocholine (DPEPC) and dioleoylphosphatidylethanolamine (DOPE). Both lipids were purchased from Avanti Polar Lipids (Alabaster, AL). Lipofectin[®] and Lipofectamine[®] and DMRIE-C[®] were obtained in a ready to use form from Life Technologies Inc. (Gaithersburg, MD). Plasmid pCMVCAT which contains the human cytomegalovirus promoter and the chloramphenicol acetyl transferase gene was provided by Life Technologies (Gaithersburg, MD). Plasmid DNA was prepared by large scale extraction from E. coli and purified by CsCl banding by Lofstrand Labs Limited (Gaithersburg, MD). In a preliminary set of experiments the ratios of the two lipids as well as the ratio of lipid to DNA was optimized by measuring the levels of gene expression in HeLa cells following transfection with the pCMVCAT plasmid using DPEPC/DOPE in a ratio of 1:1, with a lipid to DNA ratio of 6:1 (the lipid and DNA combination collectively being referred to as DPDO). The liposomes were prepared by suspending the dried lipids in water and lyophilizing the mixed lipids and resuspending the lipids in water. The rehydrated lipids were agitated at about 2,000 r.p.m. on a dental amalgamator (Heavy duty #6 Wig-L-Bug Crescent Dental, Lyons, IL) for 5 minutes and then extruded through two 0.8 micron polycarbonate filters (Nucleopore Costar, Cambridge, MA) using an Extruder Device (Lipex Biomembranes, Vancouver, B.C., Canada) at about 30 psi. For preparation of perfluorocarbon (PFC) filled liposomes, 100 microliters, 50, 25 or 12.5 microliters of PFC was added to the lipid solution prior to

shaking on the dental amalgamator. PFC's which were tested included perfluoropentane, perfluorohexane, 1-bromononafluorobutane, perfluorooctylbromide and perfluoromethylbutylether.

In vivo experiments were carried out in 50 male Balb/C mice. The body weight of the mice was 15-20g. The lipoplex was formed in the same manner as for cell transfection using the DPEPC/DOPE lipid mixture. The perfluorocarbon used in this experiment was perfluorohexane. The mixture was injected intramuscularly at a dose of 200 μ l per hind leg. The ultrasound (US) was applied at 1 W/cm² for one minute to each leg in the animals that received ultrasound. The animals were held for 2 days and then euthanized by carbon dioxide asphyxiation. The hind legs were removed from the animals and the muscle collected. The muscle was frozen in liquid nitrogen and ground in a mortar and pestle. The tissue was transferred to a pre-weighed 50 ml conical tube and the tissue weight was recorded. The tissue was then placed into one ml of the lysis buffer from the CAT ELISA kit. The CAT ELISA was then carried out according to the manufacturer's protocol. The data was transferred into Microsoft Excel and converted into ng CAT protein per gram of tissue. Statistical analysis was carried out using the JMP 3.1.5 statistical analysis package for the Macintosh.

The results are shown in Figure 7. As the figure shows, the use of a perfluorocarbon (with or without ultrasound) greatly enhanced CAT expression in mice.

The disclosures of each patent, patent application and publication cited or described in this document are hereby incorporated herein by reference, in their entirety.

Various modifications of the invention, in addition to those described herein, will be apparent to those skilled in the art from the foregoing description. Such modifications are also intended to fall within the scope of the appended claims.

Claims**What is claimed is:**

1. A method for delivering a compound into a cell comprising administering to the cell a composition which comprises the compound to be delivered
5 and an organic halide.
2. A method of claim 1 wherein said composition further comprises a carrier.
3. A method of claim 2 wherein said organic halide is selected from the group consisting of a gaseous organic halide and a liquid organic halide.
- 10 4. A method of claim 2 wherein said organic halide is a gas.
5. A method of claim 2 wherein said organic halide is a liquid.
6. A method of claim 2 wherein said organic halide is a gaseous precursor.
7. A method of claim 2 wherein said organic halide is a fluorinated
15 compound.
8. A method of claim 2 wherein said organic halide is a perfluorinated compound.
9. A method of claim 2 wherein said organic halide is a perfluorocarbon.
- 20 10. A method of claim 2 wherein said organic halide is a perfluoroether compound.

11. A method of claim 9 wherein said perfluorocarbon is a liquid.
12. A method of claim 11 wherein said liquid perfluorocarbon is a gaseous precursor.
13. A method of claim 9 wherein said perfluorocarbon is a gas.
- 5 14. A method of claim 2 wherein said organic halide is selected from the group consisting of 1-bromo-nonafluorobutane, perfluorooctyl iodide, perfluorooctyl bromide, 1-chloro-1-fluoro-1-bromomethane, 1,1,1-trichloro-2,2,2-trifluoroethane, 1,2-dichloro-2,2-difluoroethane, 1,1-dichloro-1,2-difluoroethane, 1,2-dichloro-1,1,3-trifluoropropane, 10 1-bromoperfluorobutane, 1-bromo-2,4-difluorobenzene, 2-iodo-1,1,1-trifluoroethane, 5-bromovaleryl chloride, 1,3-dichlorotetrafluoroacetone, bromine pentafluoride, 1-bromo-1,1,2,3,3,3-hexafluoropropane, 2-chloro 1,1,1,4,4,4-hexafluoro-2-butene, 2-chloropentafluoro-1,3-butadiene, iodotrifluoroethylene, 1,1,2-trifluoro-2-chloroethane, 1,2-difluorochloroethane, 1,1-difluoro-2-chloroethane, 15 1,1-dichlorofluoroethane, heptafluoro-2-iodopropane, bromotrifluoroethane, chlorotrifluoromethane, dichlorodifluoromethane, dibromofluoromethane, chloropentafluoroethane, bromochlorodifluoromethane, dichloro-1,1,2,2-tetrafluoroethane, 1,1,1,3,3-pentafluoropentane, perfluorotributylamine, perfluorotripropylamine, 3-fluorobenzaldehyde, 2-fluoro-5-nitrotoluene, 20 3-fluorostyrene, 3,5-difluoroaniline, 2,2,2-trifluoroethylacrylate, 3-(trifluoromethoxy)-acetophenone, 1,1,2,2,3,3,4,4-octafluorobutane, 1,1,1,3,3-pentafluorobutane, 1-fluorobutane, 1,1,2,2,3,3,4,4-octafluorobutane, 1,1,1,3,3-pentafluorobutane, perfluoro-4 methylquinolizidine, perfluoro-N-methyl-decahydroquinone, perfluoro-N-methyl-decahydroisoquinone, perfluoro-N-cyclohexyl- 25 pyrrolidine, tetradecaperfluoroheptane, dodecaperfluorocyclohexane, perfluoromethane, perfluoroethane, perfluoropropane, perfluorobutane, perfluoropentane, perfluorohexane, perfluoroheptane, perfluorooctane, perfluorononane, perfluorodecane, perfluorododecane, perfluoro-2-methyl-2-pentene, perfluorocyclohexane, perfluorodecalin, perfluorododecalin, perfluoropropylene, perfluorocyclobutane,

perfluoro-2-butyne, perfluoro-2-butene, perfluorobuta-1,3-diene, perfluorobutylethyl ether, bis(perfluoroisopropyl) ether, bis(perfluoropropyl) ether, perfluorotetrahydropyran, perfluoromethyl tetrahydrofuran, perfluoro t-butyl methyl ether, perfluoro isobutyl methyl ether, perfluoro n-butyl methyl ether, perfluoro
5 isopropyl ethyl ether, perfluoro n-propyl ethyl ether, perfluoro cyclobutyl methyl ether, perfluoro cyclopropyl ethyl ether, perfluoro isopropyl methyl ether, perfluoro n-propyl methyl ether, perfluoro diethyl ether, perfluoro cyclopropyl methyl ether, perfluoro methyl ethyl ether, perfluoro dimethyl ether, sulfur hexafluoride, and selenium hexafluoride.

10 15. A method of claim 2 wherein said organic halide is selected from the group consisting of perfluoromethane, perfluoroethane, perfluoropropane, perfluorobutane, perfluoropentane, perfluorohexane, perfluoroheptane, perfluorooctane, perfluorononane, perfluorodecane, perfluorododecane, perfluoro-2-methyl-2-pentene, perfluorocyclohexane, perfluorodecalin, perfluorododecalin, tetradecaperfluorohexane,
15 and dodecaperfluorocyclohexane.

16. A method of claim 2 wherein said organic halide is selected from the group consisting of perfluorobutylethyl ether, bis(perfluoroisopropyl) ether, bis(perfluoropropyl) ether, perfluorotetrahydropyran, perfluoromethyl tetrahydrofuran, perfluoro t-butyl methyl ether, perfluoro isobutyl methyl ether, perfluoro n-butyl
20 methyl ether, perfluoro isopropyl ethyl ether, perfluoro n-propyl ethyl ether, perfluoro cyclobutyl methyl ether, perfluoro cyclopropyl ethyl ether, perfluoro isopropyl methyl ether, perfluoro n-propyl methyl ether, perfluoro diethyl ether, perfluoro cyclopropyl methyl ether, perfluoro methyl ethyl ether, and perfluoro dimethyl ether.

17. A method of claim 2 wherein said organic halide is selected from
25 the group consisting of perfluorohexane and perfluorocyclohexane.

18. A method of claim 2 further comprising applying ultrasound to said cell.

19. A method of claim 18 wherein said ultrasound is applied at a frequency from about 40 kilohertz to about 25 megahertz, and an energy level of from about 500 milliwatts/cm² to about 10 watts/cm².

20. A method of claim 18 wherein said ultrasound is applied at a frequency of from about 500 kilohertz to about 200 kilohertz and said energy level is from about 500 milliwatts/cm² to about 200 milliwatts/cm².

21. A method of claim 18 wherein said ultrasound is applied at a frequency of from about 20 megahertz to about 1 megahertz and said energy level is from about 200 milliwatts/cm² to about 100 milliwatts/cm².

22. A method of claim 21 wherein said ultrasound is applied at a duty cycle of from about 1% to about 100% of the treatment time.

23. A method of claim 18 wherein said compound and said ultrasound are administered and applied simultaneously.

24. A method of claim 2 wherein said carrier is selected from the group consisting of polymers, lipids, proteins, and metal ions.

25. A method of claim 24 wherein said carrier is a protein.

26. A method of claim 25 wherein said protein is a cationic protein.

27. A method of claim 26 wherein said cationic protein is selected from the group consisting of polylysine and polyethyleneimine.

28. A method of claim 24 wherein said carrier is a lipid.

29. A method of claim 28 wherein said lipid is a cationic lipid.

30. A method of claim 29 wherein the carrier is a cationic lipid and said cationic lipid is N-[1(2,3-dioleoyloxy)propyl]-N,N,N-trimethylammonium chloride.

31. A method of claim 28 wherein said lipid is a fluorinated lipid.

32. A method of claim 31 wherein said fluorinated lipid is selected
5 from compounds of the formula

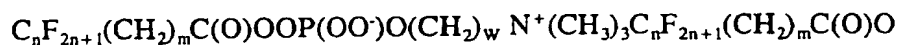

wherein: m is 0 to about 18, n is 1 to about 12; and w is 1 to about 8.

33. A method of claim 28 wherein said lipid is a fluorinated phospholipid.

10 34. A method of claim 24 wherein said carrier is a polymer.

35. A method of claim 34 wherein said polymer is selected from the group consisting of polyethylenes, polyoxyethylenes, polypropylenes, pluronic acids and alcohols, polyvinyls, polyvinylpyrrolidone, arabinans, fructans, fucans, galactans, galacturonans, glucans, mannans, xylans, levan, fucoidan, carrageenan,
15 galactocarolose, pectin, pectic acid, amylose, pullulan, glycogen, amylopectin, cellulose, carboxymethylcellulose, hydroxypropyl methylcellulose, dextran, pustulan, chitin, agarose, keratan, chondroitin, dermatan, hyaluronic acid, alginic acid, homopolymers and heteropolymers containing one or more of an aldose, ketose, acid,
amine, erythrose, threose, ribose, arabinose, xylose, lyxose, allose, altrose, glucose,
20 mannose, gulose, idose, galactose, talose, erythrulose, ribulose, xylulose, psicose, fructose, sorbose, tagatose, glucuronic acid, gluconic acid, glucaric acid, galacturonic acid, mannuronic acid, guluronic acid, glucosamine, galactosamine and neuraminic acid.

36. A method of claim 24 wherein said carrier is a metal ion.

37. A method of claim 24 wherein said carrier is a metal ion and said metal ion is selected from the group consisting of calcium ions, magnesium ions, and zinc ions.

38. A method of claim 2 wherein said carrier is selected from the group
5 consisting of Lipofectin, Lipofectamine, Transfectace, Transfectam, Cytofectin, DMRIE, DLRIE, GAP-DLRIE, DOTAP, DOPE, DMEAP, DODMP, DOPC, DDAB, DOSPA, EDLPC, EDMPC, DPH, TMADPH, CTAB, lysyl-PE, DC-Chol, -alanyl cholesterol, DCGS, DPPE, DCPE, DMAP, DMPE, DOGS, DOHME, DPEPC, Pluronic, Tween, BRIJ, plasmalogen, phosphatidylethanolamine, phosphatidylcholine,
10 glycerol-3-ethylphosphatidylcholine, dimethyl ammonium propane, trimethyl ammonium propane, diethylammonium propane, triethylammonium propane, dimethyldioctadecylammonium bromide, a sphingolipid, sphingomyelin, a lysolipid, a glycolipid, a sulfatide, a glycosphingolipid, cholesterol, cholesterol ester, cholesterol salt, oil, N-succinyldioleoylphosphatidylethanolamine, 1,2,-dioleoyl-sn-glycerol,
15 1,3-dipalmitoyl-2-succinylglycerol, 1,2-dipalmitoyl-sn-3-succinylglycerol, 1-hexadecyl-2-palmitoylglycerophosphatidylethanolamine, palmitoylhomocystiene, N,N'-Bis (dodecylaminocarbonylmethylene)-N,N'-bis ((-N,N,N-trimethylammoniummethyl-aminocarbonylmethylene)ethylenediamine tetraiodide; N,N''-Bis (hexadecylaminocarbonylmethylene)-N,N',N''-tris
20 ((-N,N,N-trimethylammonium-ethylaminocarbonylmethylenediethylenetriamine hexaiodide; N,N'-Bis (dodecylaminocarbonylmethylene)-N,N''-bis((-N,N,N-trimethylammoniummethylaminocarbonylmethylene)cyclohexylene-1,4-diamine tetraiodide; 1,1,7,7-tetra-((-N,N,N,N-tetramethylammoniummethylamino-carbonylmethylene)-3-hexadecylaminocarbonyl-methylene-1,3,7-triaazaheptane
25 heptaoidide; and N,N,N',N'-tetra((-N,N,N-trimethylammonium-ethylaminocarbonylmethylene)-N'-(1,2-dioleoylglycero-3-phosphoethanolaminocarbonylmethylene) diethylenetriamine tetraiodide.

39. A method of claim 2 wherein said carrier is selected from the group consisting of dioleoylphosphatidylethanolamine, a fatty acid, a lysolipid,
30 phosphatidylcholine, phosphatidylethanolamine, phosphatidylserine,

phosphatidylglycerol, phosphatidylinositol, a sphingolipid, a glycolipid, a glucolipid, a sulfatide, a glycosphingolipid, phosphatidic acid, palmitic acid, stearic acid, arachidonic acid, oleic acid, a lipid bearing a polymer, a lipid bearing a sulfonated saccharide, cholesterol, tocopherol hemisuccinate, a lipid with an ether-linked fatty acid, a lipid with an ester-linked fatty acid, a polymerized lipid, diacetyl phosphate, 5 stearylamine, cardiolipin, a phospholipid with a fatty acid of 6-8 carbons in length, a phospholipid with asymmetric acyl chains, 6-(5-cholesten-3 β -yloxy)-1-thio-b-D-galactopyranoside, digalactosyldiglyceride, 6-(5-cholesten-3 β -yloxy)hexyl-6-amino-6-deoxy-1-thio-b-D-galactopyranoside, 6-(5-cholesten-3 β -yloxy)hexyl-10 6-amino-6-deoxy-1-thio- α -D-mannopyranoside, 12-(((7'-diethylamino-coumarin-3-yl)carbonyl)methylamino)-octadecanoic acid; N-[12-(((7'-diethylaminocoumarin-3-yl)carbonyl)methyl-amino) octadecanoyl]-2-aminopalmitic acid; cholesteryl)4'-trimethyl-ammonio)butanoate; N-succinyldioleoyl-phosphatidylethanolamine; 1,2-dioleoyl-sn-glycerol; 1,2-dipalmitoyl-sn-3-succinyl-glycerol; 15 1,3-dipalmitoyl-2-succinylglycerol; 1-hexadecyl-2-palmitoylglycerophosphoethanolamine, palmitoylhomocysteine, and/or combinations thereof.

40. A method of claim 39 wherein said carrier comprises phosphatidylcholine and said phosphatidylcholine is selected from the group consisting of dioleoylphosphatidylcholine, dimyristoylphosphatidylcholine, 20 dipentadecanoylphosphatidylcholine, dilauroylphosphatidylcholine, dioleoylphosphatidylcholine, dipalmitoylphosphatidylcholine, and distearoylphosphatidylcholine.

41. A method of claim 39 wherein said carrier comprises phosphatidylethanolamine and said phosphatidylethanolamine is 25 dioleoylphosphatidylethanolamine.

42. A method of claim 39 wherein said carrier comprises sphingolipid and said sphingolipid is sphingomyelin.

43. A method of claim 39 wherein said carrier comprises a glycolipid and said glycolipid is selected from ganglioside GM1 and ganglioside GM2.
44. A method of claim 39 wherein said carrier comprises a lipid bearing polymer and said polymer of said lipid bearing a polymer is selected from the group consisting of polyethylene glycol, chitin, hyaluronic acid, and polyvinylpyrrolidone.
45. A method of claim 44 wherein said polymer is polyethylene glycol and said polyethylene glycol is selected from the group consisting of polyethylene glycol having a molecular weight of about 2000, 5000, and 8000.
46. A method of claim 39 wherein said carrier comprises a lipid bearing a sulfonated saccharide.
47. A method of claim 39 wherein said carrier comprises cholesterol and said cholesterol is selected from the group consisting of cholesterol sulfate and cholesterol hemisuccinate.
48. A method of claim 39 wherein said carrier comprises a phospholipid with asymmetric acyl chains and said phospholipid with asymmetric acyl chains is a phospholipid having one acyl chain of about 6 carbons in length and another acyl chain of about 12 carbons in length.
49. A method of claim 2 wherein said carrier comprises about 82 mole percent dipalmitoylphosphatidylcholine, about 8 mole percent dipalmitoylphosphatidylethanolamine-polyethyleneglycol 5000 and about 10 mole percent dipalmitoylphosphatidic acid.
50. A method of claim 2 wherein said carrier is a surfactant.
51. A method of claim 50 where said surfactant is a fluorosurfactant.

52. A method of claim 2 wherein said organic halide is a gaseous precursor and wherein said gaseous precursor is converted to a gas after administration.

53. A method of claim 52 wherein said gaseous precursor is converted
5 to a gas by applying heat to said cell.

54. A method of claim 53 wherein said heat is applied by ultrasound.

55. A method of claim 54 wherein said ultrasound is applied at a frequency from about from 40 kilohertz to about 25 megahertz, and said energy level is from about 500 milliwatts/cm² to about 10 watts/cm².

10 56. A method of claim 54 wherein said ultrasound is applied at a frequency of from about 500 kilohertz to about 200 kilohertz and said energy level is from about 500 milliwatts/cm² to about 200 milliwatts/cm².

57. A method of claim 54 wherein said ultrasound is applied at a frequency of from about 20 megahertz to about 1 megahertz and said energy level is
15 from about 200 milliwatts/cm² to about 100 milliwatts/cm².

58. A method of claim 54 wherein said ultrasound is applied at a duty cycle of from about 1% to about 100% treatment time.

59. A method of claim 54 wherein said ultrasound is applied at a duty cycle of from about 10% to about 20%.

20 60. A method of claim 2 wherein said method is carried out *in vivo*.

61. A method of claim 2 wherein said method is carried out *ex vivo*.

62. A method of claim 2 wherein said method is carried out *in vitro*.

63. A method of claim 2 wherein said carrier comprises a vesicle.
64. A method of claim 63 wherein said compound to be delivered is encapsulated in said vesicle.
65. A method of claim 2 wherein said cell is a mammalian cell.
- 5 66. A method of claim 65 wherein said mammalian cell is a human cell.
67. A method of claim 2 wherein said compound to be delivered is a nucleotide sequence.
68. A method of claim 67 wherein said nucleotide sequence is a DNA
10 sequence.
69. A method of claim 68 wherein said DNA sequence is selected from the group consisting of a DNA sequence coding for interleukin 2, interleukin 4, Bcl 2, vascular endothelial growth factor, human papilloma virus, and human immunodeficiency virus, human leukocyte antigen, tumor necrosis factor, granulocyte-
15 macrophage colony stimulating factor, cystic fibrosis transmembrane receptor, adenosine deaminase, luteinizing hormone releasing hormone, luteinizing hormone releasing hormone antagonist, human growth hormone, insulin, high density lipoprotein, thymidine kinase, HLA-B7, Factor VIII, and *ras/p53*.
70. A method of claim 68 wherein said DNA sequence is administered
20 for the purpose of treating a disease selected from the group consisting of acquired immune deficiency syndrome, hemophilia, muscular dystrophy, cystic fibrosis, diabetes, atherosclerosis, liver cancer, lung cancer, prostate cancer, ovarian cancer, brain cancer, kidney cancer melanoma, neuroblastoma, and breast cancer.

71. A method of claim 68 wherein said DNA sequence is administered by an inhaler for the purpose of treating cystic fibrosis.

72. A method of claim 68 wherein said DNA sequence is administered upon a balloon catheter for the purpose of treating atherosclerosis.

5 73. A method of claim 68 wherein said DNA sequence codes for vascular endothelial growth factor and said DNA sequence is administered in combination with a carrier wherein said carrier is a hydrogel.

10 74. A method of claim 68 wherein said DNA sequence codes for interleukin-2 and said DNA sequence is administered in combination with a cationic liposome.

75. A method of claim 68 wherein said DNA sequence is administered for the purpose of treating muscular dystrophy.

15 76. A method of claim 68 wherein said DNA sequence codes for Bcl 2 and said DNA sequence is administered for the purpose of treating colon cancer.

77. A method of claim 2 wherein the compound to be delivered is a bioactive agent.

78. A method of claim 2 wherein the compound to be delivered is a diagnostic agent.

20 79. A method of claim 2 wherein the compound to be delivered is a pharmaceutical agent.

80. A method of claim 2 wherein said method is carried out concurrently with another intracellular delivery technique selected from the group

consisting of calcium phosphate precipitation, transfection with a viral vector, microinjection and electroporation.

81. A method of claim 18 wherein said method is carried out concurrently with another intracellular delivery technique selected from the group
5 consisting of calcium phosphate precipitation, transfection with a viral vector, microinjection and electroporation.

82. A method of effecting the expression of a nucleotide sequence in a cell comprising administering to said cell a composition comprising a nucleotide sequence and an organic halide.

10 83. A method of claim 82 wherein said composition further comprises a carrier.

84. A method of claim 83 further comprising the step of applying ultrasound.

85. A method of claim 83 wherein said cell is a mammalian cell.

15 86. A method of claim 83 wherein said cell is a human cell.

87. A method of treating a patient comprising administering to the patient a composition comprising a therapeutically effective amount of a compound and an organic halide.

20 88. A method according to claim 87 further comprising the step of applying ultrasound.

89. A composition comprising a therapeutically effective amount of a compound and an organic halide.

90. A composition of claim 89 further comprising a carrier.
91. A composition comprising a diagnostically effective amount of a compound and an organic halide.
92. A composition of claim 91 further comprising a carrier.
- 5 93. A kit comprising an organic halide and a carrier.
94. A kit of claim 93 further comprising a compound to be delivered to a cell.
95. A kit of claim 93 further comprising conventional kit components.
96. A kit comprising an organic halide and a compound to be delivered
10 to a cell.
97. A kit of claim 96 further comprising a carrier.
98. A kit of claim 96 further comprising conventional kit components.
99. A method for delivering a compound into a cell comprising administering to the cell the compound to be delivered, and applying ultrasound.
- 15 100. A method of claim 99 wherein said compound is in a composition which further comprises a carrier.
101. A method of treating a patient comprising administering to a patient a therapeutically effective amount of a compound, and applying ultrasound.
102. A method of claim 101 wherein said compound is in a composition
20 which further comprises a carrier.

103. A method of effecting the expression of a nucleotide sequence in a cell comprising administering to the cell a nucleotide sequence, and applying ultrasound.

104. A method of claim 103 wherein said nucleotide sequence is in a
5 composition which further comprises a carrier.

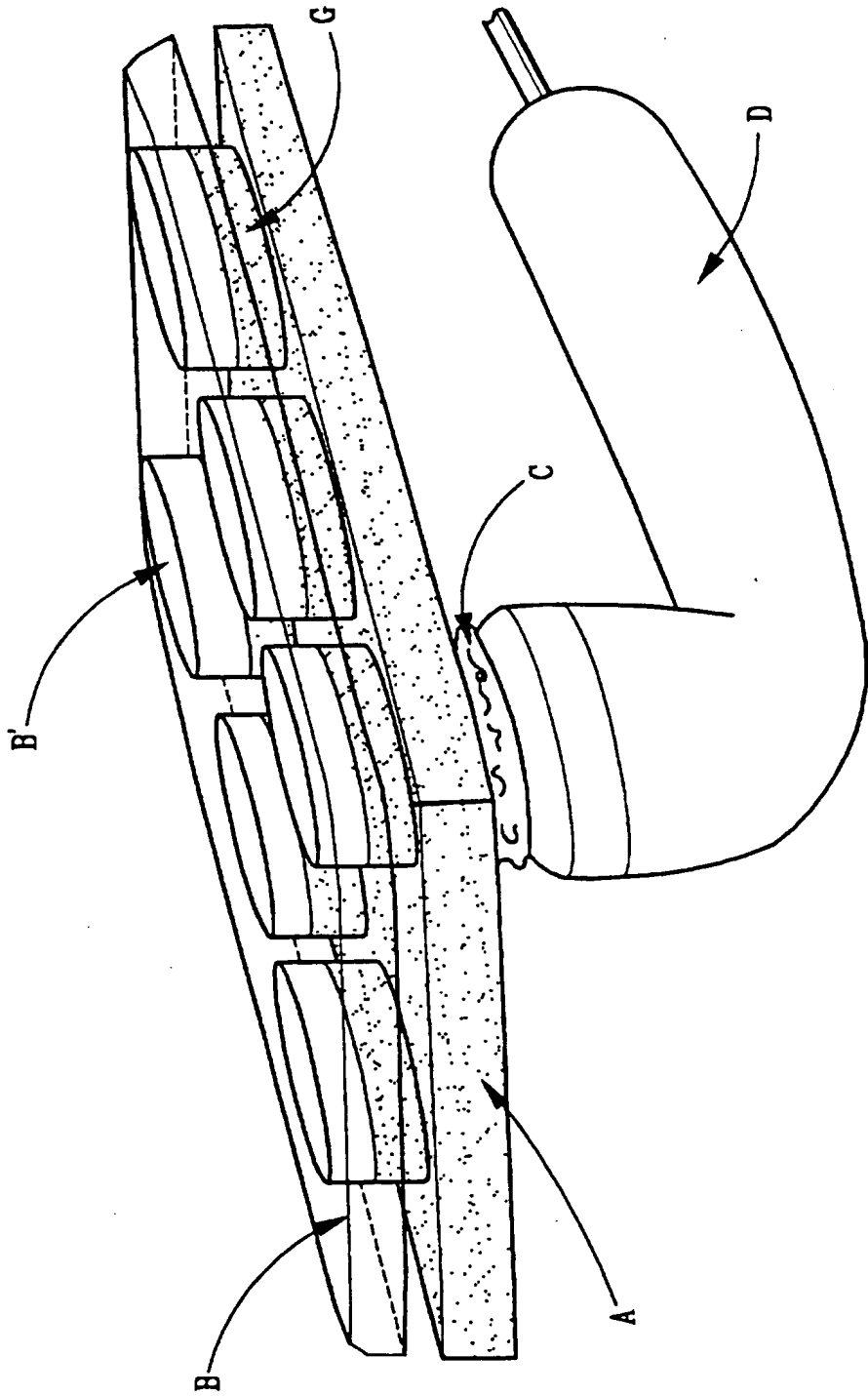
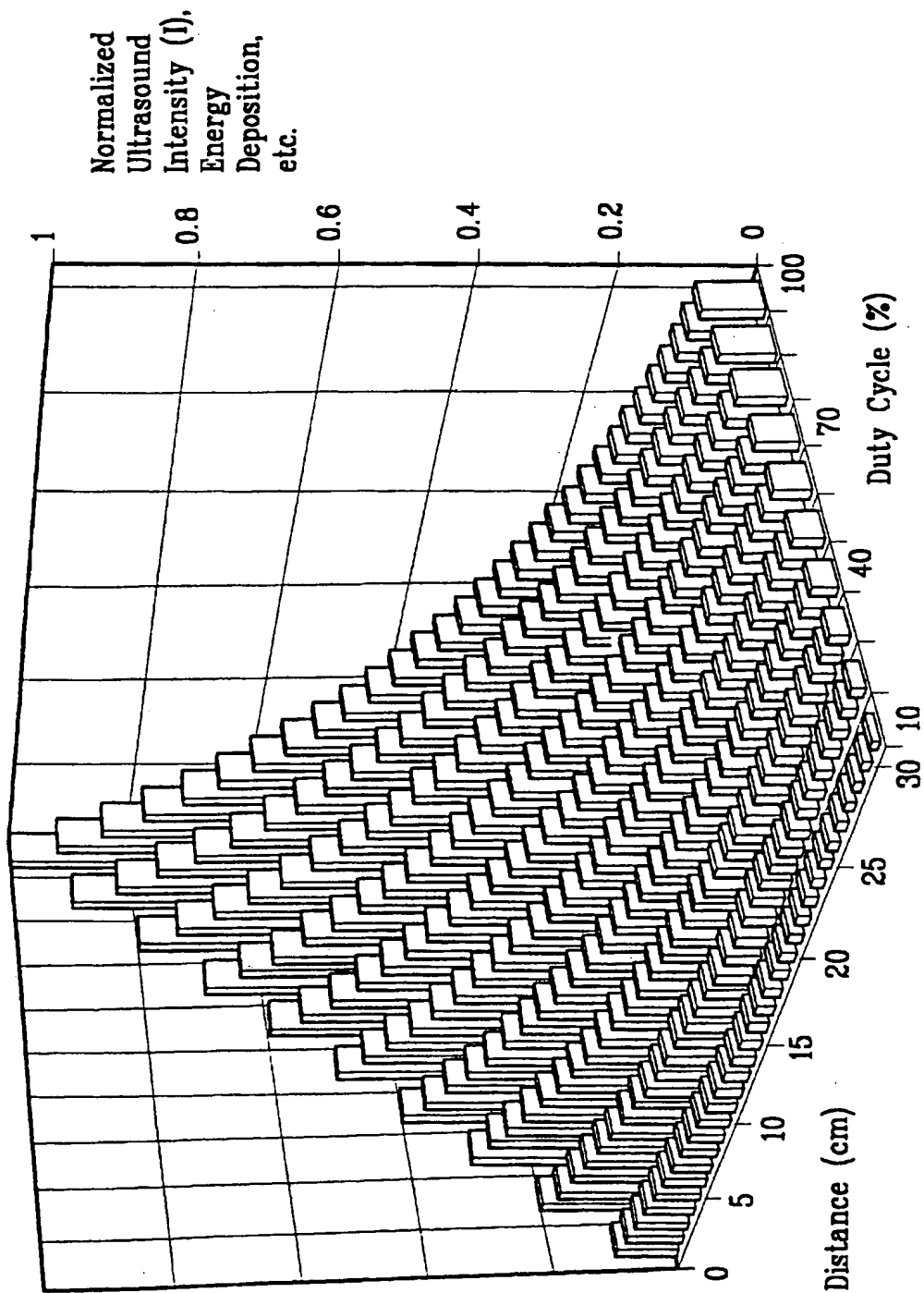

FIG. 1

FIG. 2



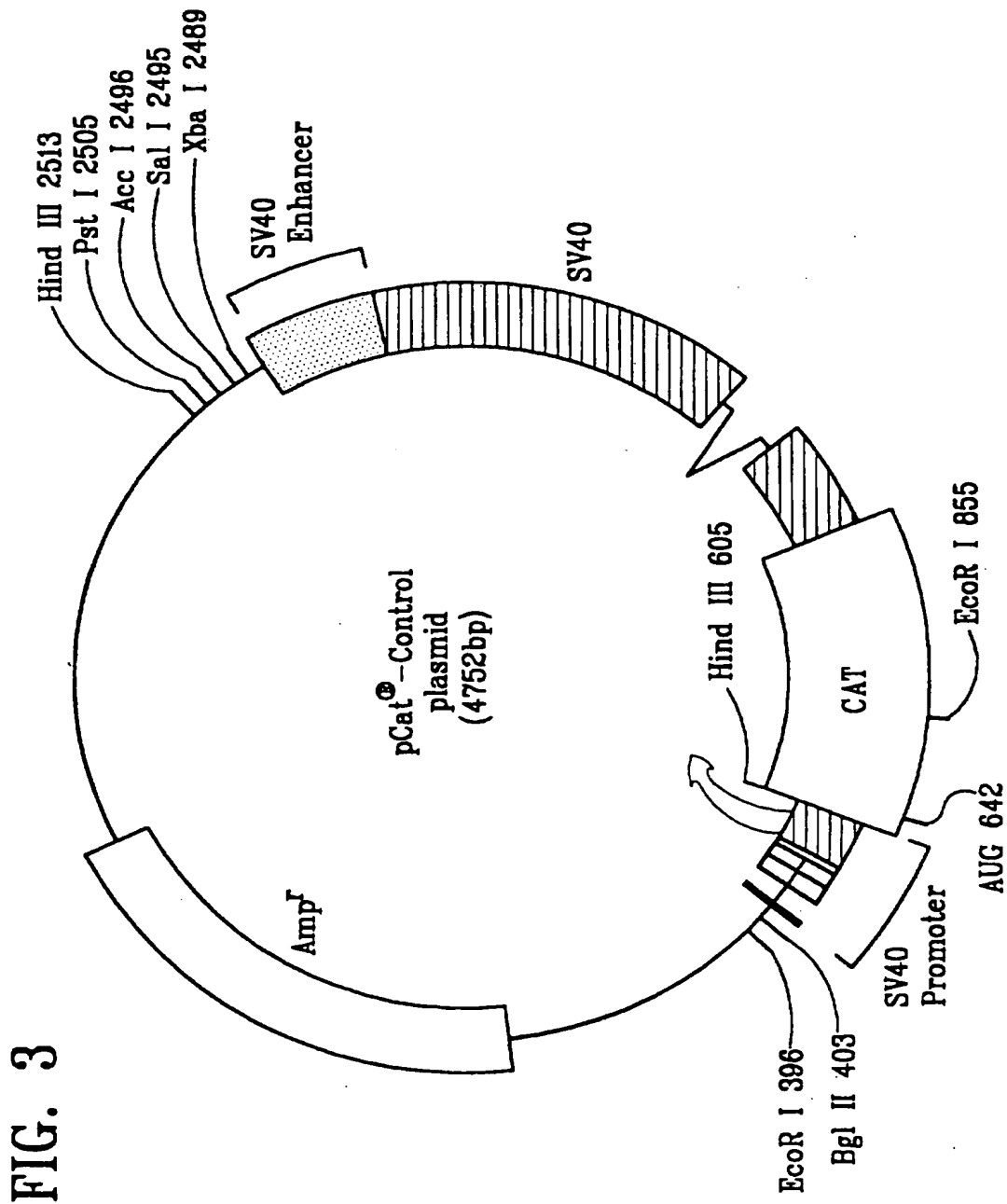

FIG. 3

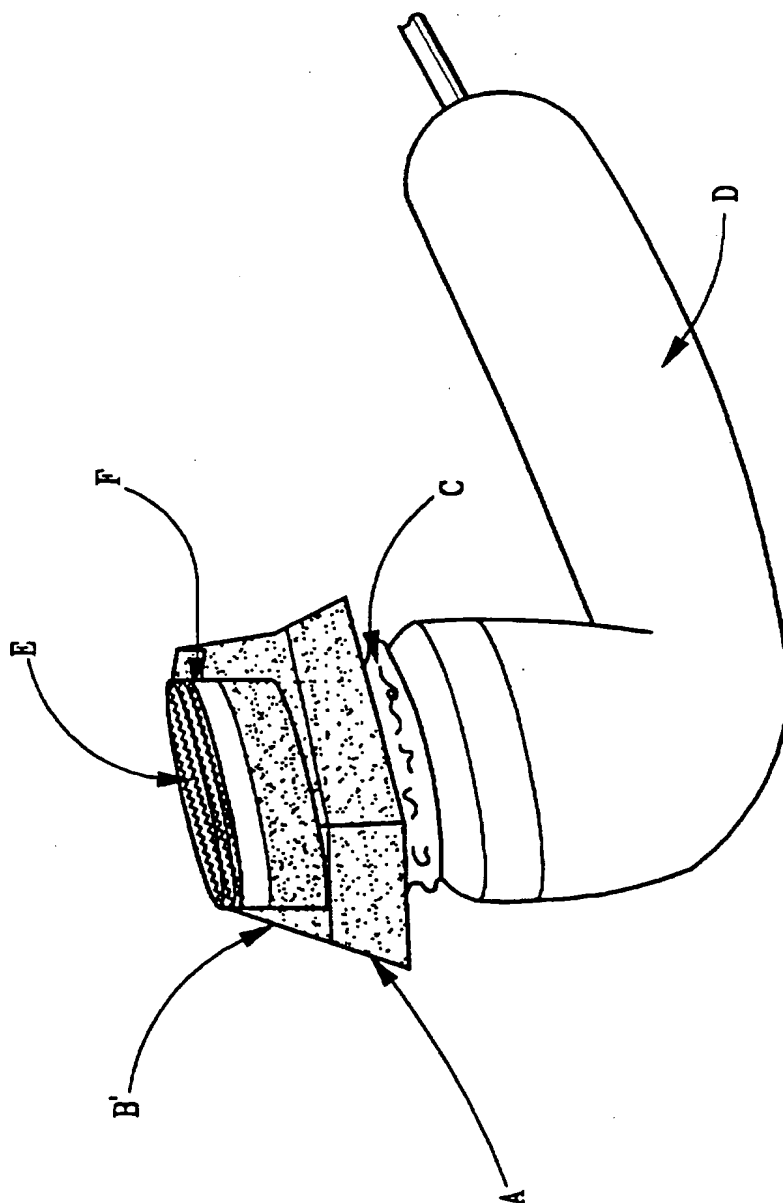

FIG. 4

5/7

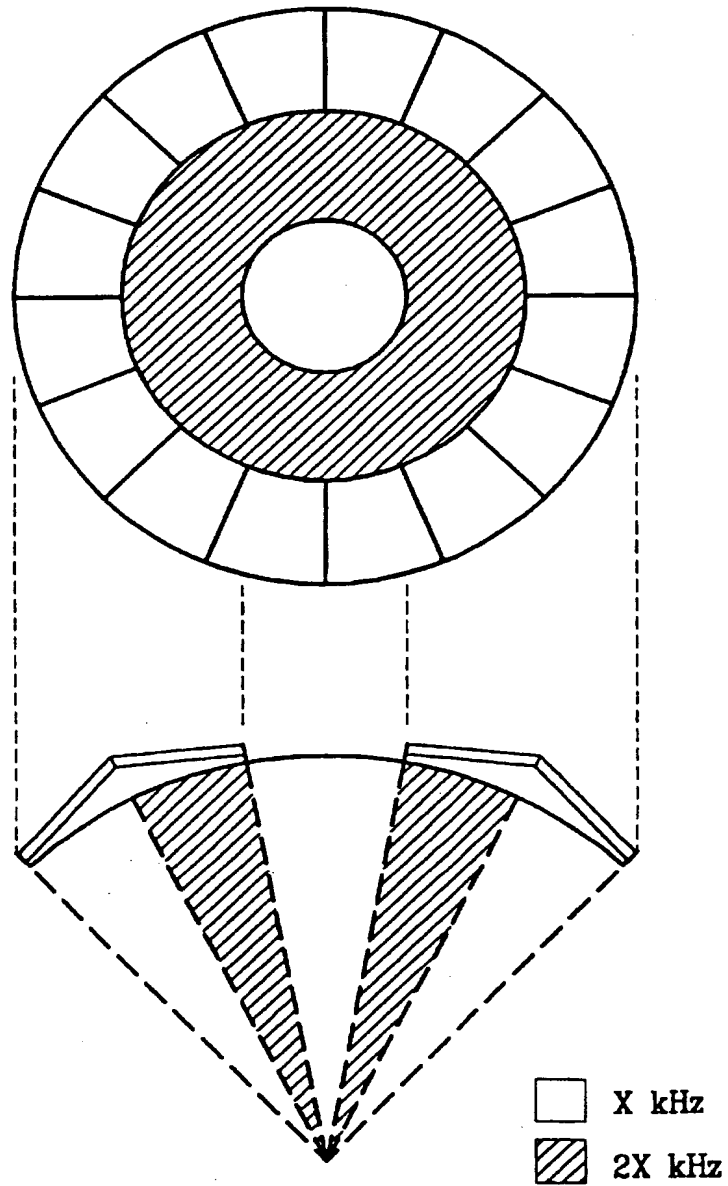

FIG. 5

SUBSTITUTE SHEET (RULE 26)

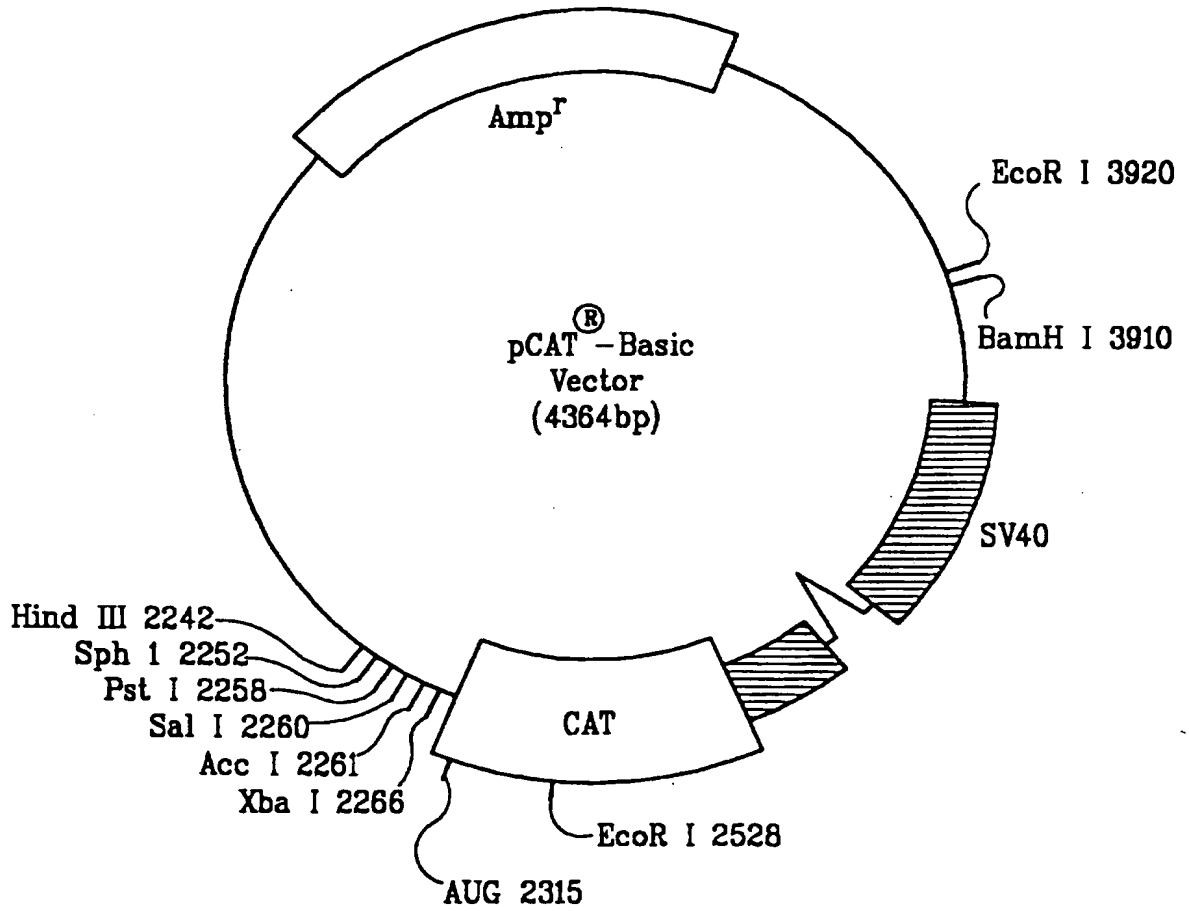

FIG. 6

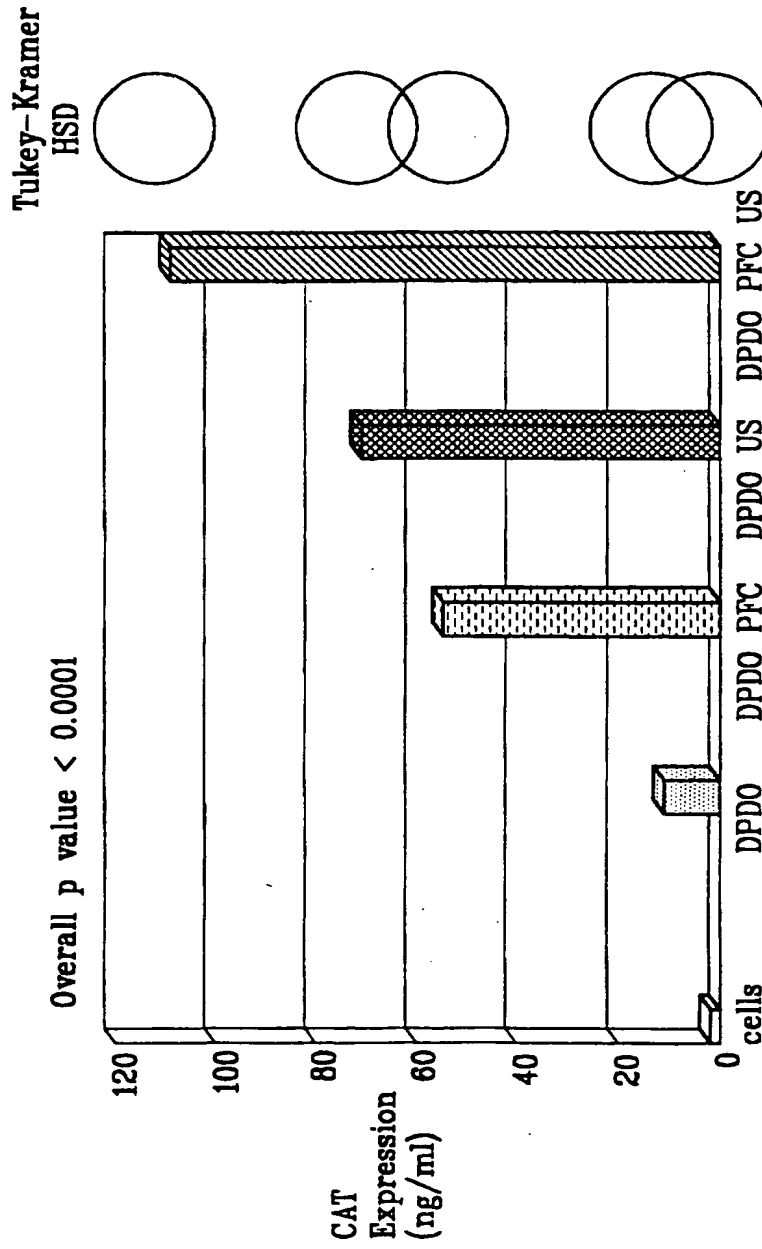

FIG. 7

INTERNATIONAL SEARCH REPORT

International application No.
PCT/US97/07237

A. CLASSIFICATION OF SUBJECT MATTER IPC(6) : A01N 43/04; A61K 31/70, 48/00; C07H 21/04; C12N 5/10, 15/12, 15/85 US CL : 514/44; 424/ 93.2, 93.21; 536/23.1, 23.2, 23.5, 435/240.2, 320.1, 172.3 According to International Patent Classification (IPC) or to both national classification and IPC		
B. FIELDS SEARCHED Minimum documentation searched (classification system followed by classification symbols) U.S. : 514/44; 424/ 93.2, 93.21; 536/23.1, 23.2, 23.5, 435/240.2, 320.1, 172.3 Documentation searched other than minimum documentation to the extent that such documents are included in the fields searched Electronic data base consulted during the international search (name of data base and, where practicable, search terms used) Please See Extra Sheet.		
C. DOCUMENTS CONSIDERED TO BE RELEVANT		
Category*	Citation of document, with indication, where appropriate, of the relevant passages	Relevant to claim No.
Y,P	US 5,532,108 A (VOGELSTEIN) 02 July 1996, see entire document.	1-104
Y	TISCHER et al. The Human Gene for Vascular Endothelial Growth Factor. J. Biol. Chem. 25 June 1991, Vol. 266, No. 18, pages 11947-11954, see entire document.	1-104
Y	RIESSEN et al. Percutaneous arterial gene transfer using pure DNA applied to a hydrogel-coated angioplasty balloon. Eur. Heart J. 1993, Vol. 14, page 78-78, abstract 590, see entire document.	1-104
<input checked="" type="checkbox"/> Further documents are listed in the continuation of Box C. <input type="checkbox"/> See patent family annex.		
* Special categories of cited documents: *A* document defining the general state of the art which is not considered to be of particular relevance *E* earlier document published on or after the international filing date *L* document which may throw doubts on priority claim(s) or which is cited to establish the publication date of another citation or other special reason (as specified) *O* document referring to an oral disclosure, use, exhibition or other means *P* document published prior to the international filing date but later than the priority date claimed	*T* later document published after the international filing date or priority date and not in conflict with the application but cited to understand the principle or theory underlying the invention *X* document of particular relevance; the claimed invention cannot be considered novel or cannot be considered to involve an inventive step when the document is taken alone *Y* document of particular relevance; the claimed invention cannot be considered to involve an inventive step when the document is combined with one or more other such documents, such combination being obvious to a person skilled in the art *&* document member of the same patent family	
Date of the actual completion of the international search 09 JUNE 1997	Date of mailing of the international search report 24 JUL 1997	
Name and mailing address of the ISA/US Commissioner of Patents and Trademarks Box PCT Washington, D.C. 20231 Facsimile No. (703) 305-3230	Authorized officer <i>Christopher S. F. Low</i> CHRISTOPHER S. F. LOW Telephone No. (703) 308-0196	

INTERNATIONAL SEARCH REPORT

International application No.
PCT/US97/07237

C (Continuation). DOCUMENTS CONSIDERED TO BE RELEVANT		
Category*	Citation of document, with indication, where appropriate, of the relevant passages	Relevant to claim No.
Y	STIEGEL et al. Percutaneous Coronary Ultrasonic Angioplasty: Initial Clinical experience. Eur. Heart J. 1993, Vol. 14, page 78, abstract 588, see the entire document.	
Y, P	US 5,542,935 A (UNGER et al.) 06 August 1996, see entire document.	1-104
Y,P	US 5,558,092 A (UNGER et al.) 24 September 1996, see entire document.	1-104
Y	WO 89/02464 A1 (AMERSHAM INTERNATIONAL PLC) 23 March 1989, see entire document.	1-104
X	US 5,149,319 A (UNGER) 22 September 1992, see entire document.	1-9, 11-14, 18, 24, 24-26, 38-41, 43, 44, 46, 47, 50-54, 58, 60-66, 77-79, 87-102
-		
Y		1-104
Y	US 4,987,154 A (LONG) 22 January 1991, see entire document.	1-104
Y	US 4,927,623 A (LONG) 22 May 1990, see entire document.	1-104
Y	US 4,865,836 A (LONG) 12 September 1989, see entire document.	1-104

INTERNATIONAL SEARCH REPORT

International application No.
PCT/US97/07237

B. FIELDS SEARCHED

Electronic data bases consulted (Name of data base and where practicable terms used):

Automated Patent System - USPAT, EPOABS, JPOABS

DIALOG - MEDLINE, BIOSIS

Search terms:

ultrasound, ultrasonic, DNA, RNA, gene, therapy, treatment, halogen, halide, haloform, perfluoro?, lipid(s), protein, peptide, polypeptide, DAG, PE, PC, PS, cholesterol?, duty cycle, virus, cytokine, interleukin, vascular, endothelial, growth factor, ADA, receptor(s), LH, LHRH, p3, factor viii, cancer, diabetes